

# KORAČNI MOTOR (STEP MOTOR)



# Osobine i vrste



Koračni motor je posebna vrsta motora kojom računar lako upravlja. Veoma je sličan sinhronom motoru. Može biti sa rotorom:

- od stalnog magneta,
- od mekog gvožđa (reluktantni motor),
- hibridni (kombinacija prva 2 tipa, radi dobijanja maksimalne snage u malom kućištu), ili
- sa namotajima i četkicama.

Prema broju faza može biti: 2, 3, 4 ili 5 fazni.

Broj koraka na punom krugu zavisi od konstrukcije, a kreće se od 10 do 500 koraka.

Prave se za snage od nekoliko W do nekoliko kW.

# Motor sa navojnim vretenom



**Za pretvaranje kružnog kretanja u pravolinijsko**

# Motor sa stepenastom osovinom

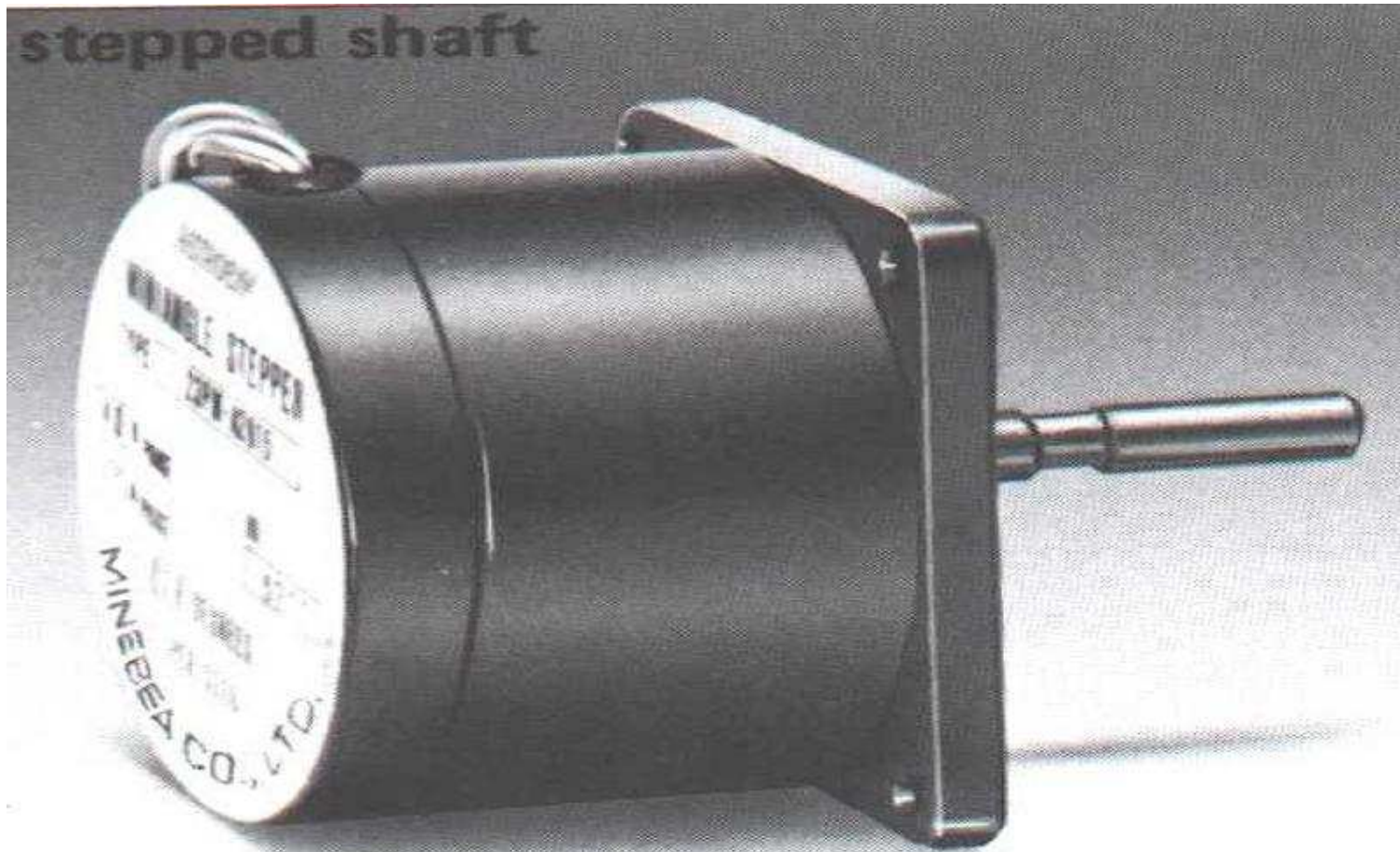
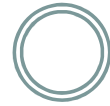



# Motor sa reduktorom



Reduktor

Motor

# Motor sa hladnjakom

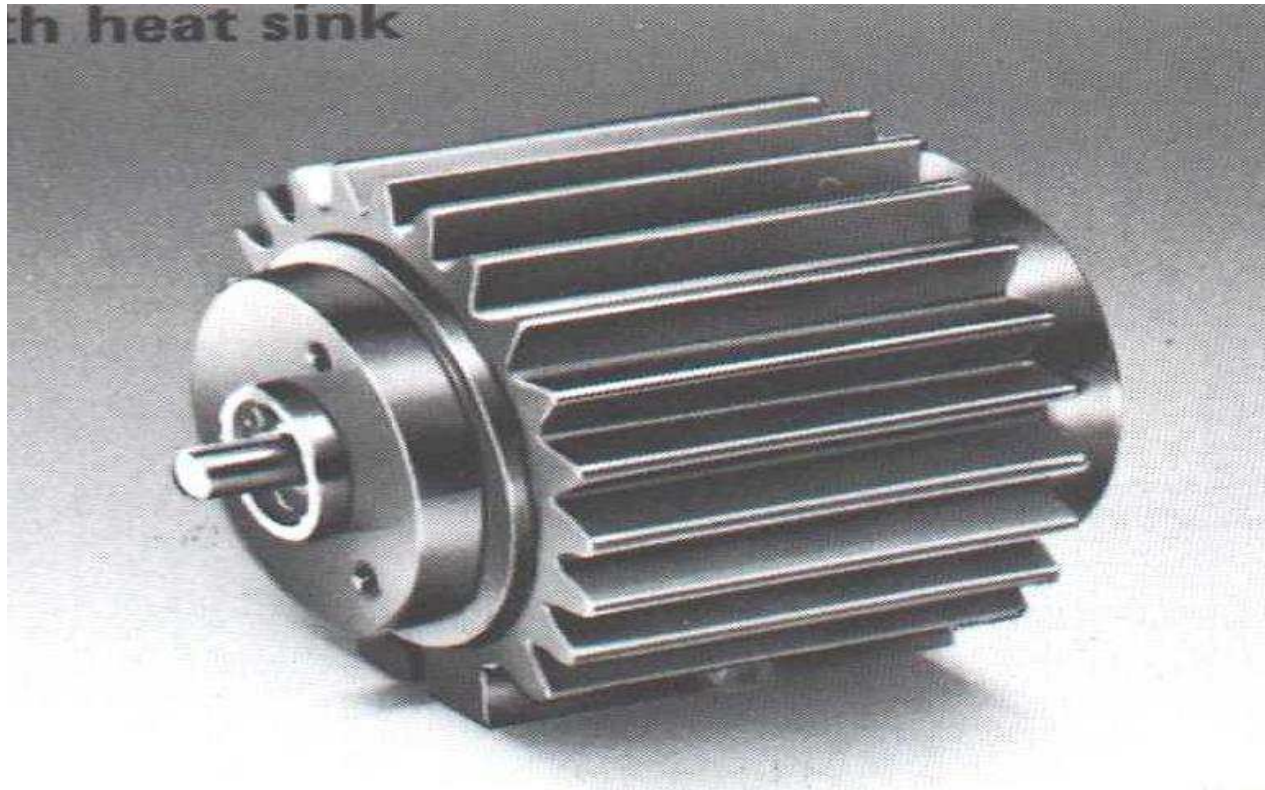

**Motor koji ima veliku gustinu snage mora imati hladnjak.**

# Motor sa linearnim pomjeranjem

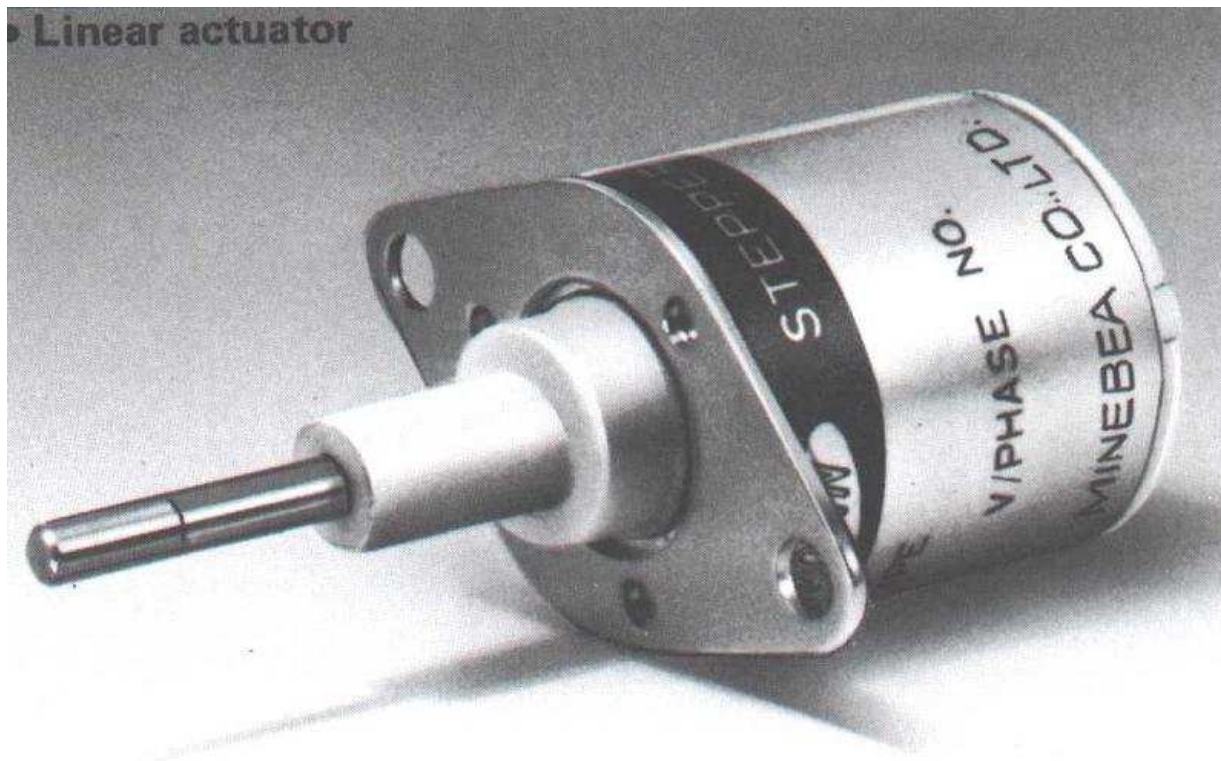

**Pomoću navoja na osovini i navoja na rotoru postignuto je da se okretanjem rotora osovina uvlači/izvlači.**

# Primjena koračnog motora



- Za precizno i jednostavno pozicioniranje svih vrsta mehanizama (od glave štampača do velikih liftova).
- Preciznost do 500 koraka po krugu ili 1000 polukoraka po krugu.
- Za još preciznije pozicioniranje – mikrokoraci
- Nije potrebna povratna sprega po položaju.
- Sistem upravljanja je jednostavan i direktan – koji položaj zadamo motoru, on će ga ostvariti.



# XY koordinatni sto

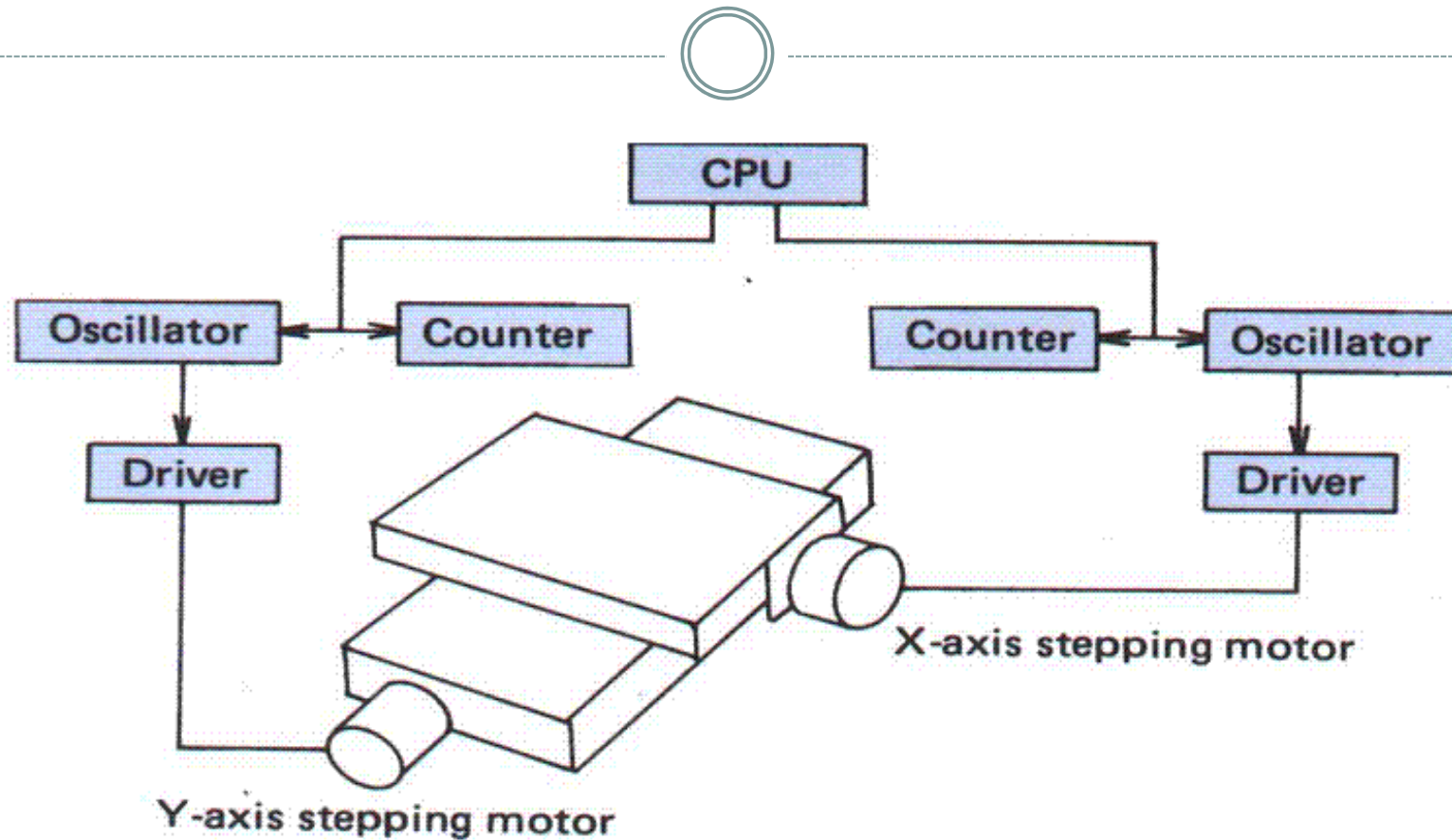

**Pomjera platformu u ravni. Jedan koračni motor pomjera po X drugi po Y osi.**

# Pomjerenje glave štampača

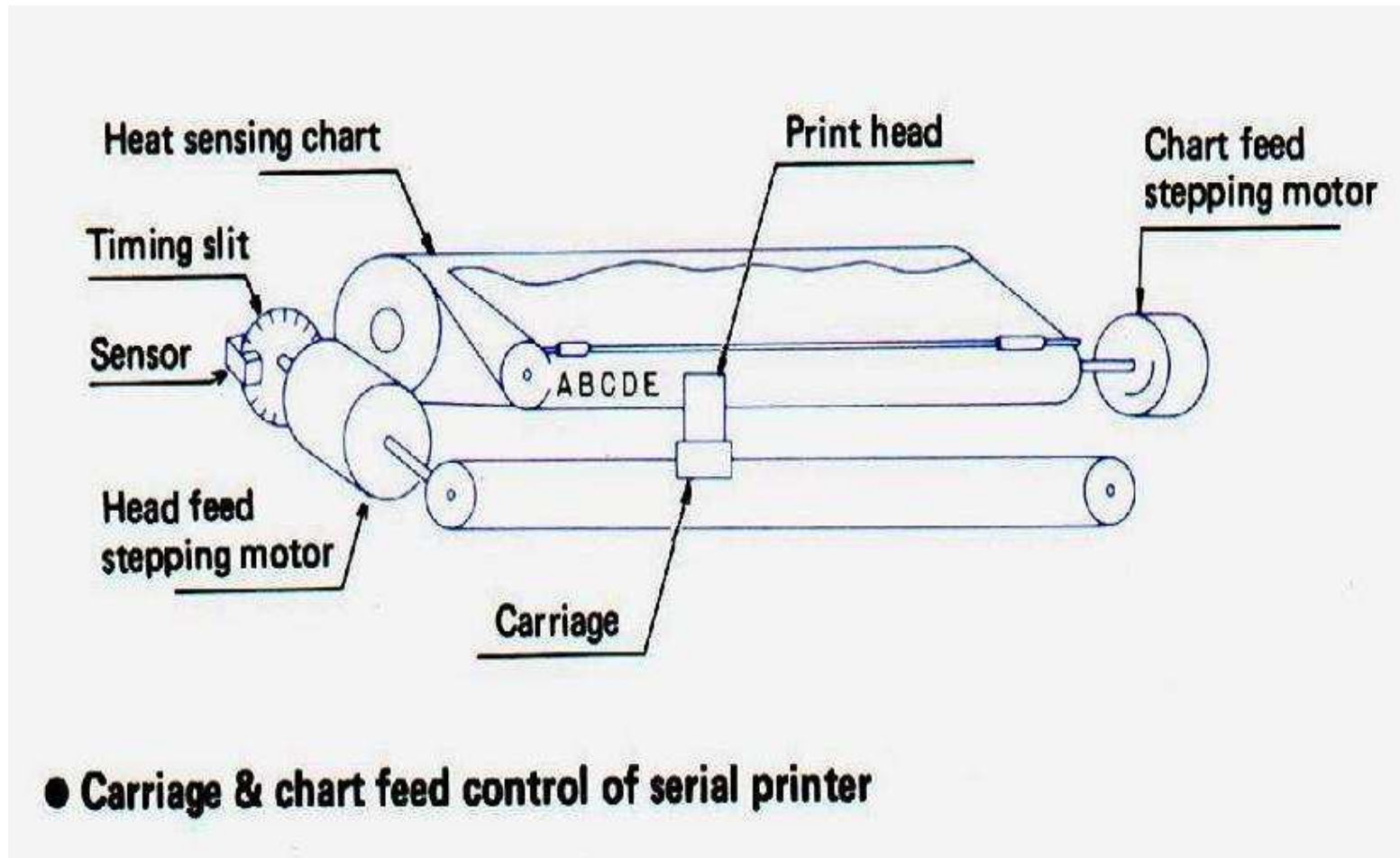

# Pomjerenje papira kod štampača

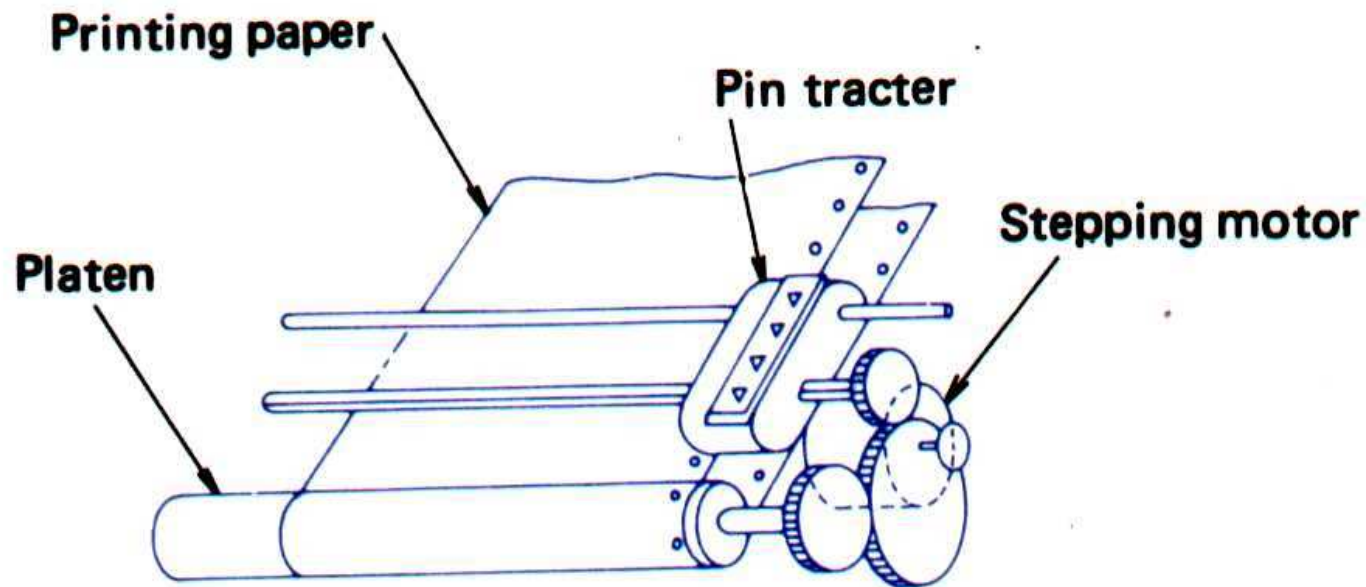

- **Chart feed control of printer**

# Fax mehanizam

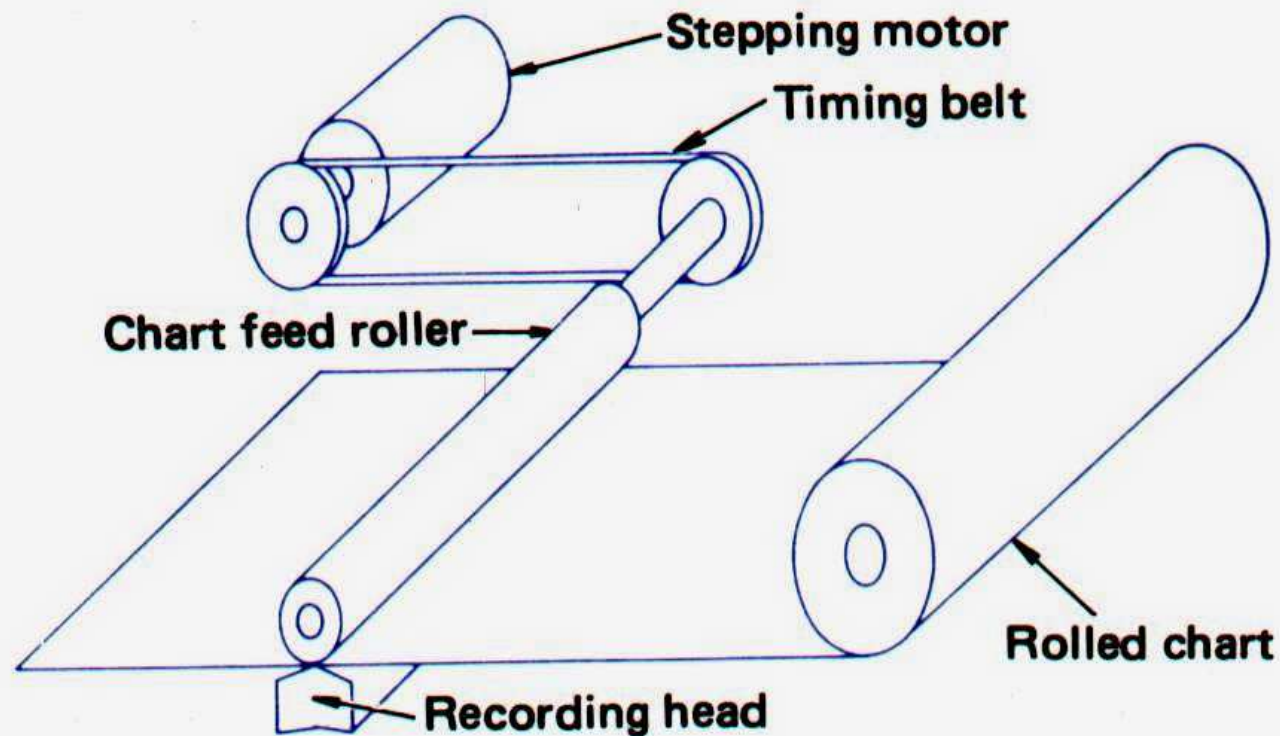

- **Chart feed in transmitting · receiving unit of facsimile**



# Pokretanje lepeze sa slovima

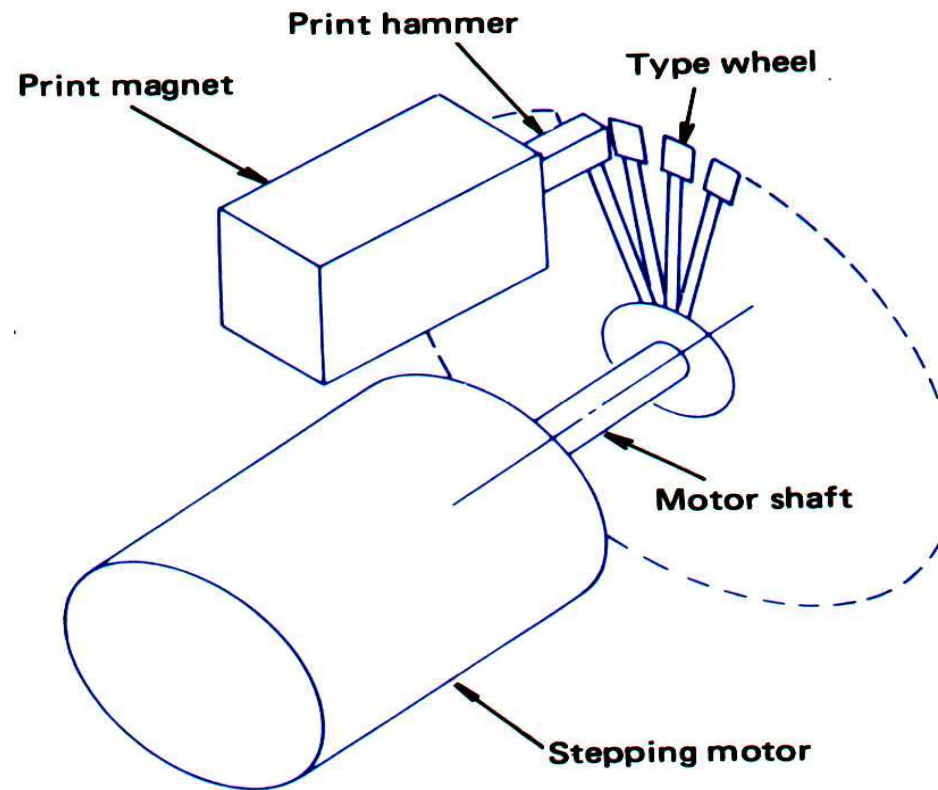

- Selection of characters in printer

**Kotačni motor okreće lepezu sa slovima.**

# Mehanizam floppyja

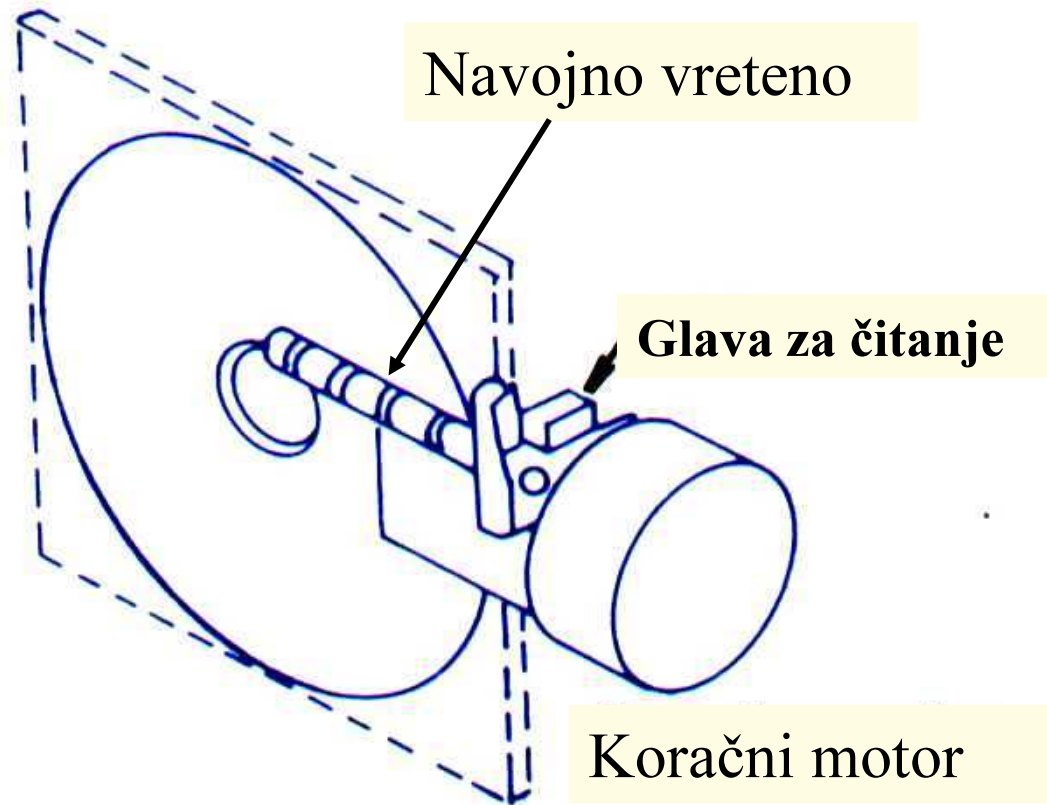

**Koračni motor pomjera magnetnu glavu i pozicionira na mjesto za čitanje**

# Kaišni prenos



Kolica koja se kreću po vodiči

Vodiča

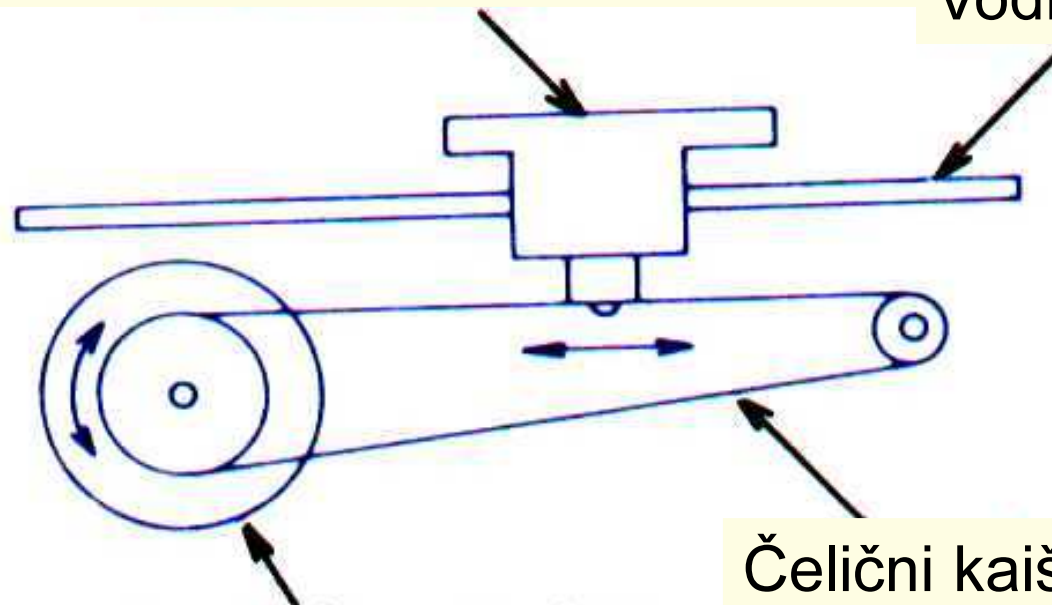

Koračni motor

Čelični kaiš

**Pretvaranje kružnog u pravolinijsko kretanje,  
kaišnim prenosom.**

# Klizni prenos



Kolica koja se kreću po vođici

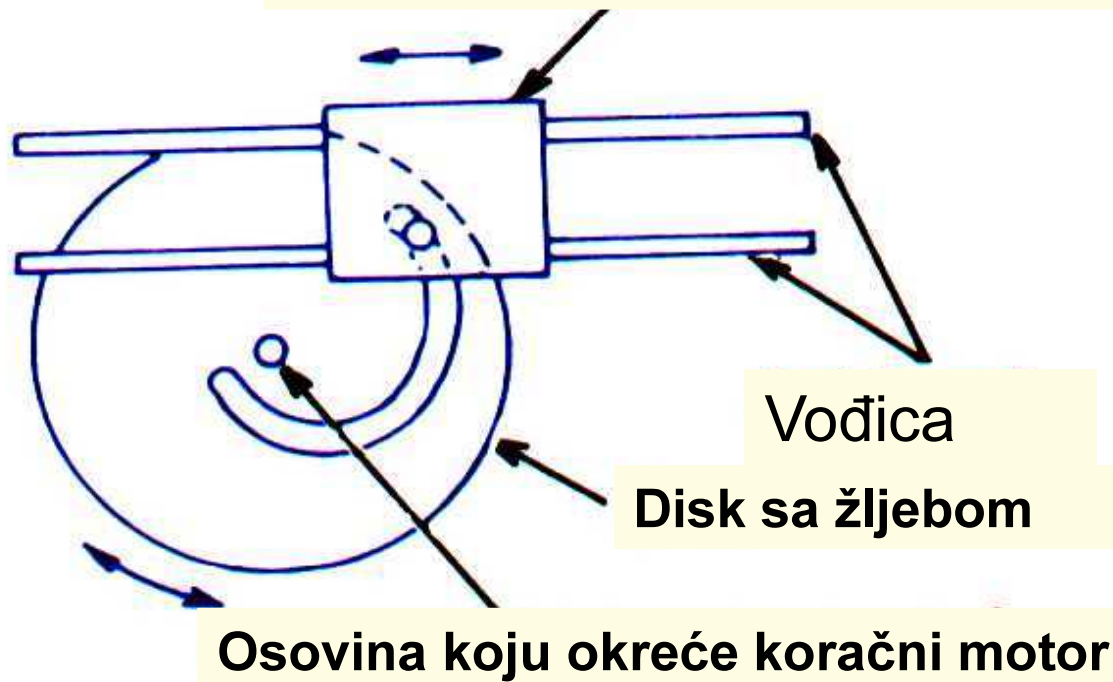

● **Cam type**



# Mehanizam plotera

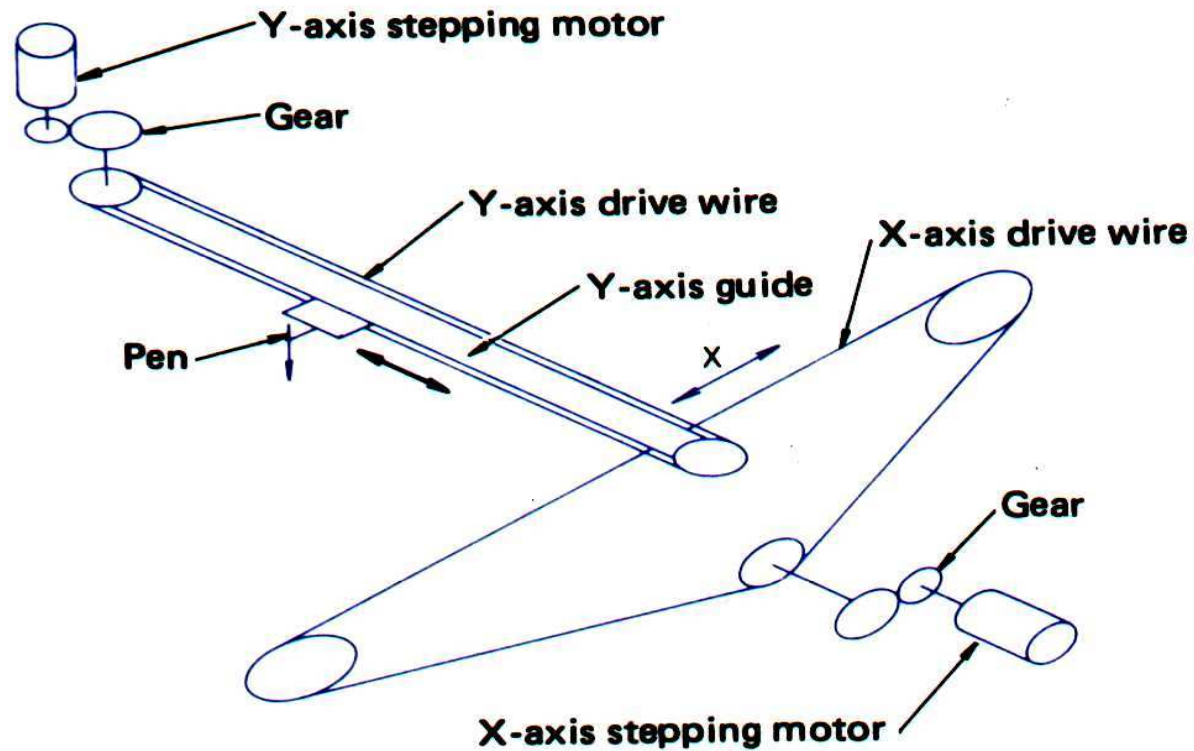

● Positional control of X-Y plotter

# Glodalica

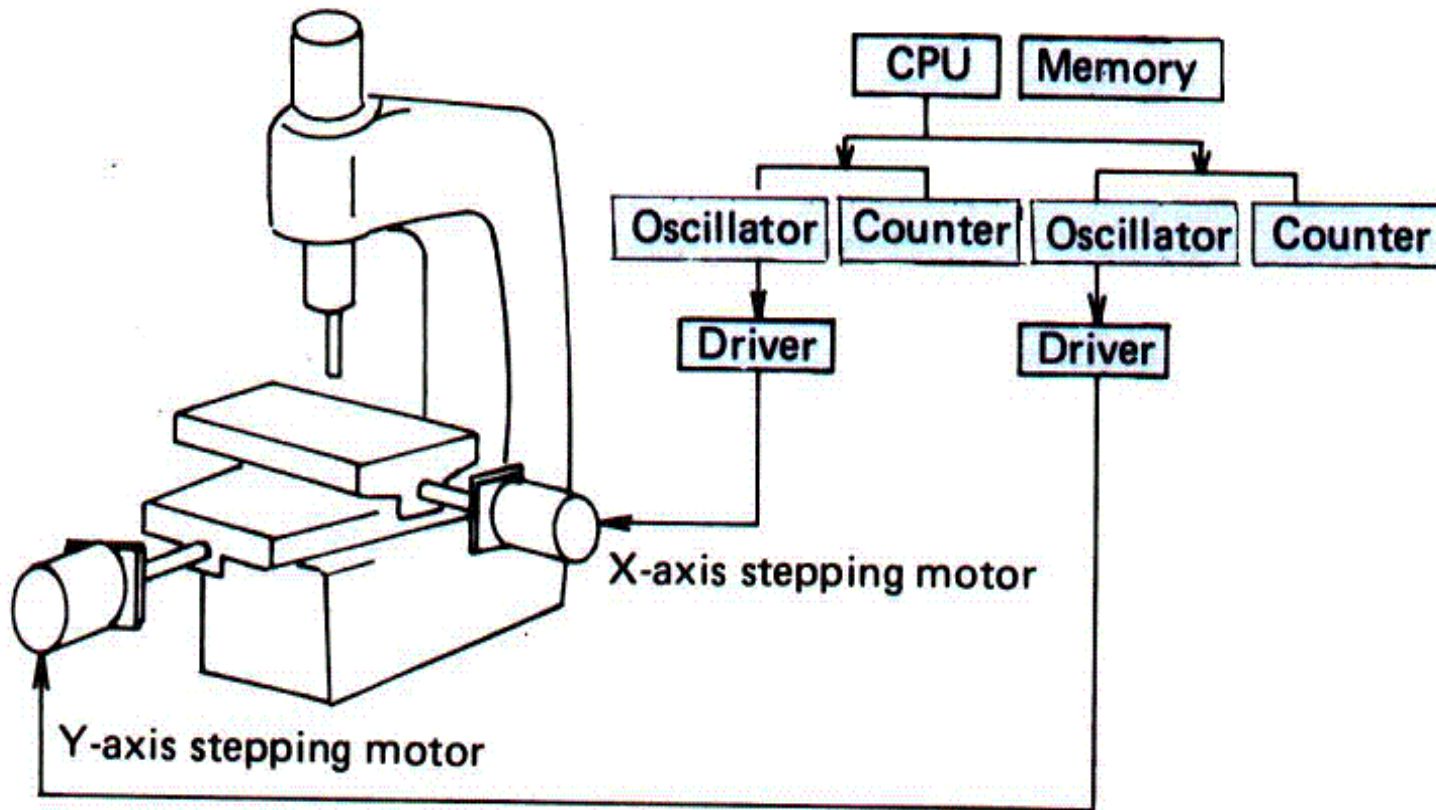

- Cross table drive of drilling machine NC)

# Koordinatna brusilica

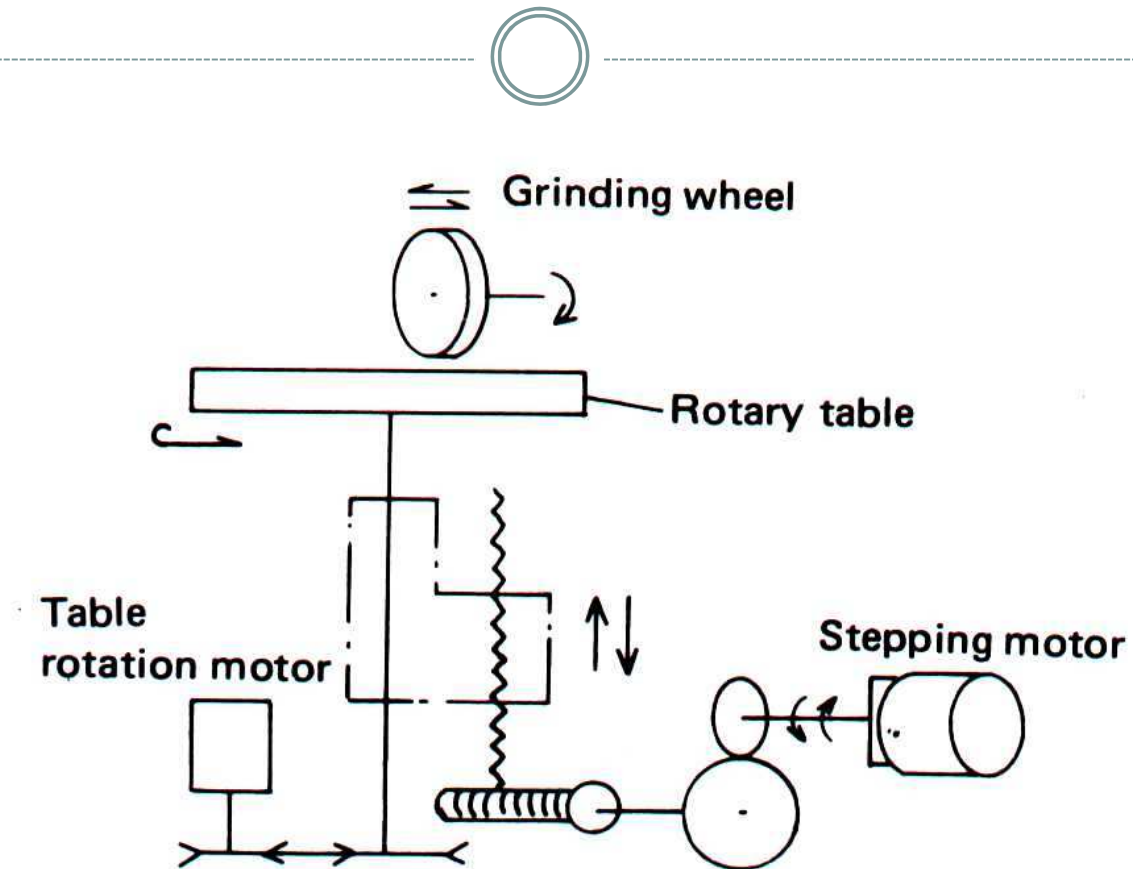

- **Table & grinding wheel feed control of rotary grinding machine**

# Šivaća mašina

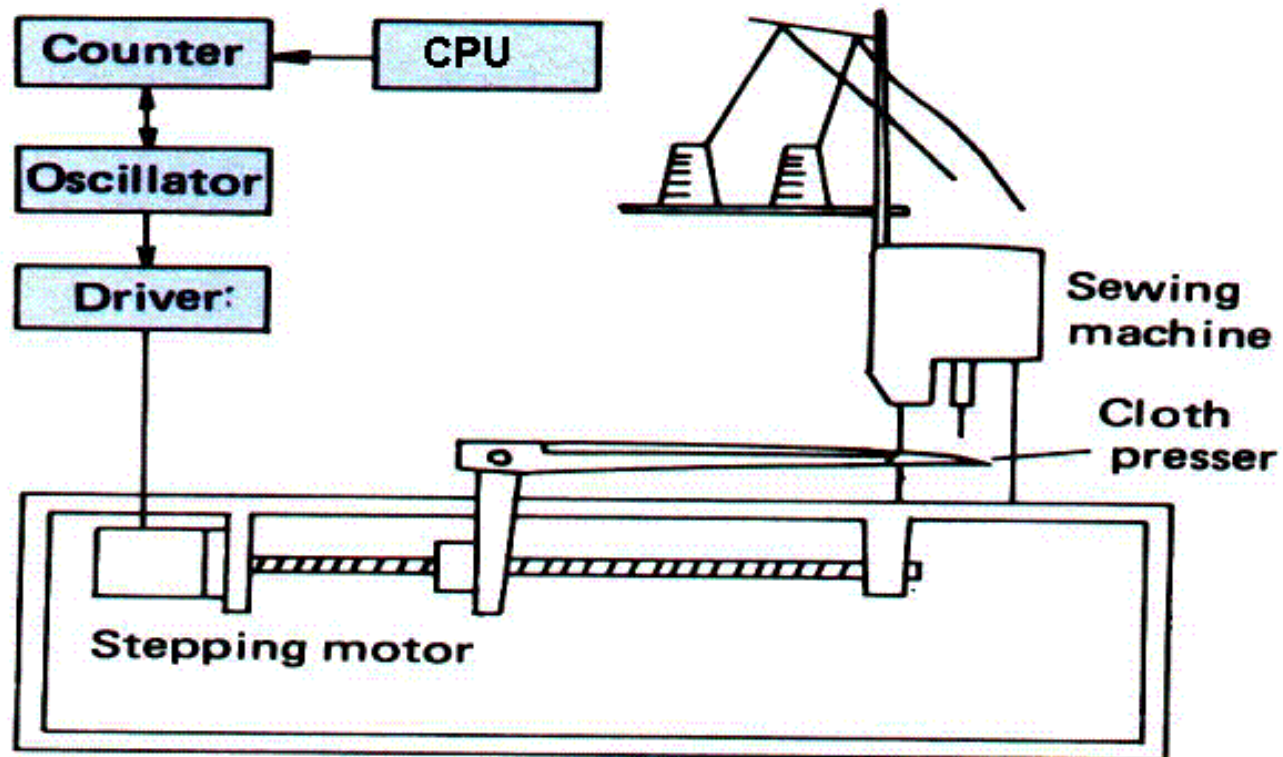

- Industrial-use sewing machine feed mechanism & pattern stitch control of knitting machine



# Koordinatni rezač

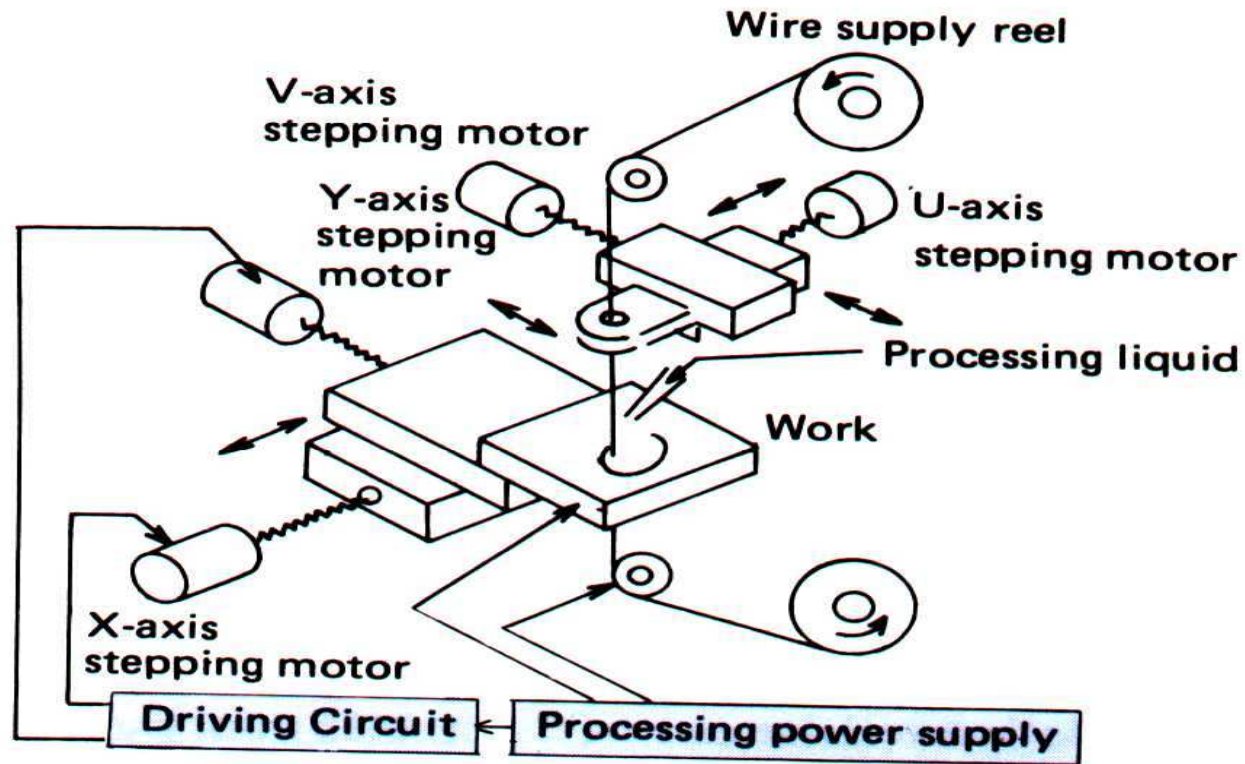

- Electric discharge machine for wire cutting

# Indeksni mehanizam

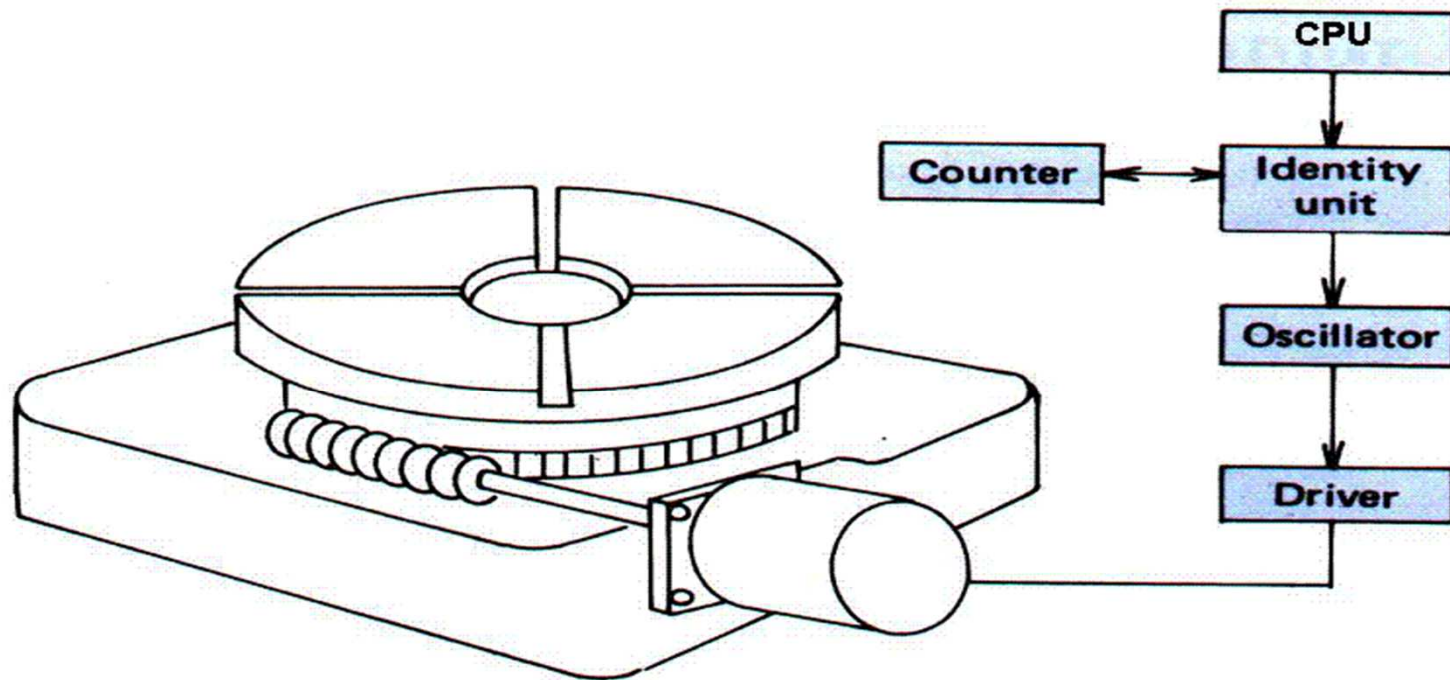

- Angle indexing control of index table

Postavlja alat univerzalnoj mašini, po radnom programu.

# Princip rada koračnog motora

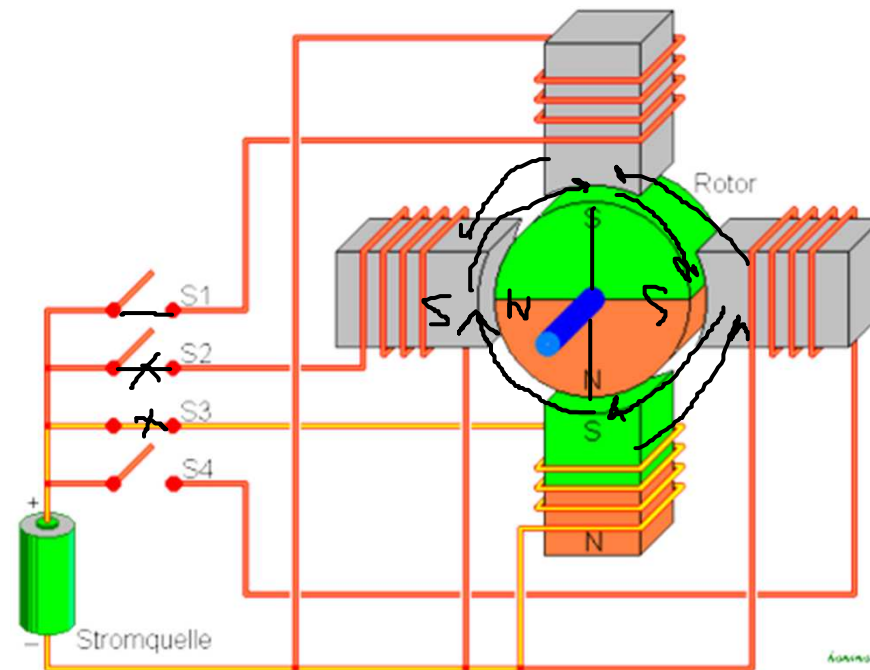
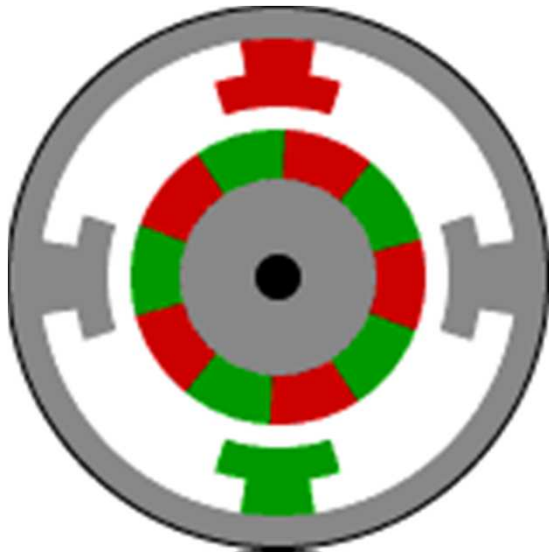

## Zatvoren prekidač P1. Struja protiče kroz L1

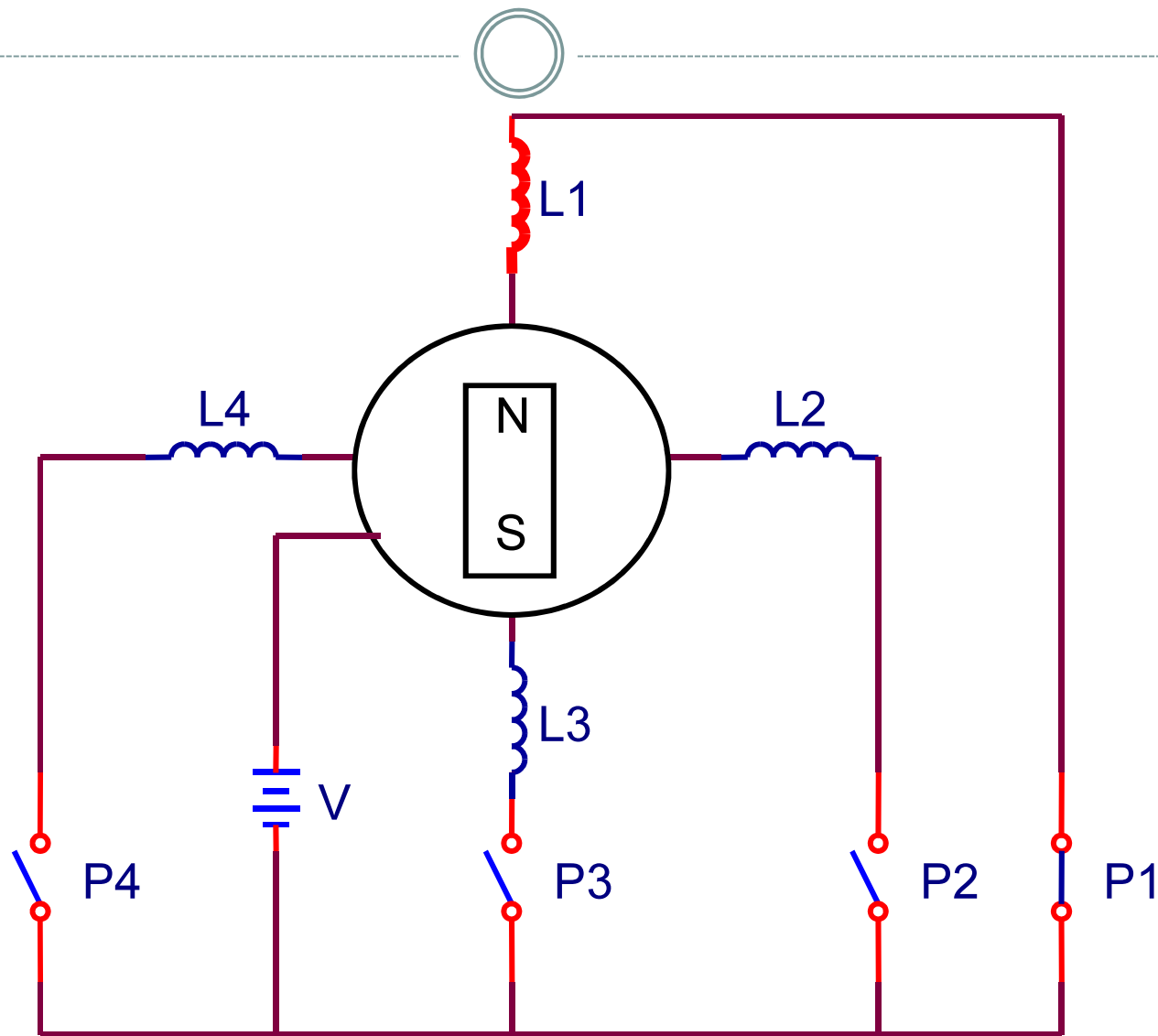

# Zatvoren prekidac P2. Struja protiče kroz L2 Napravljen korak

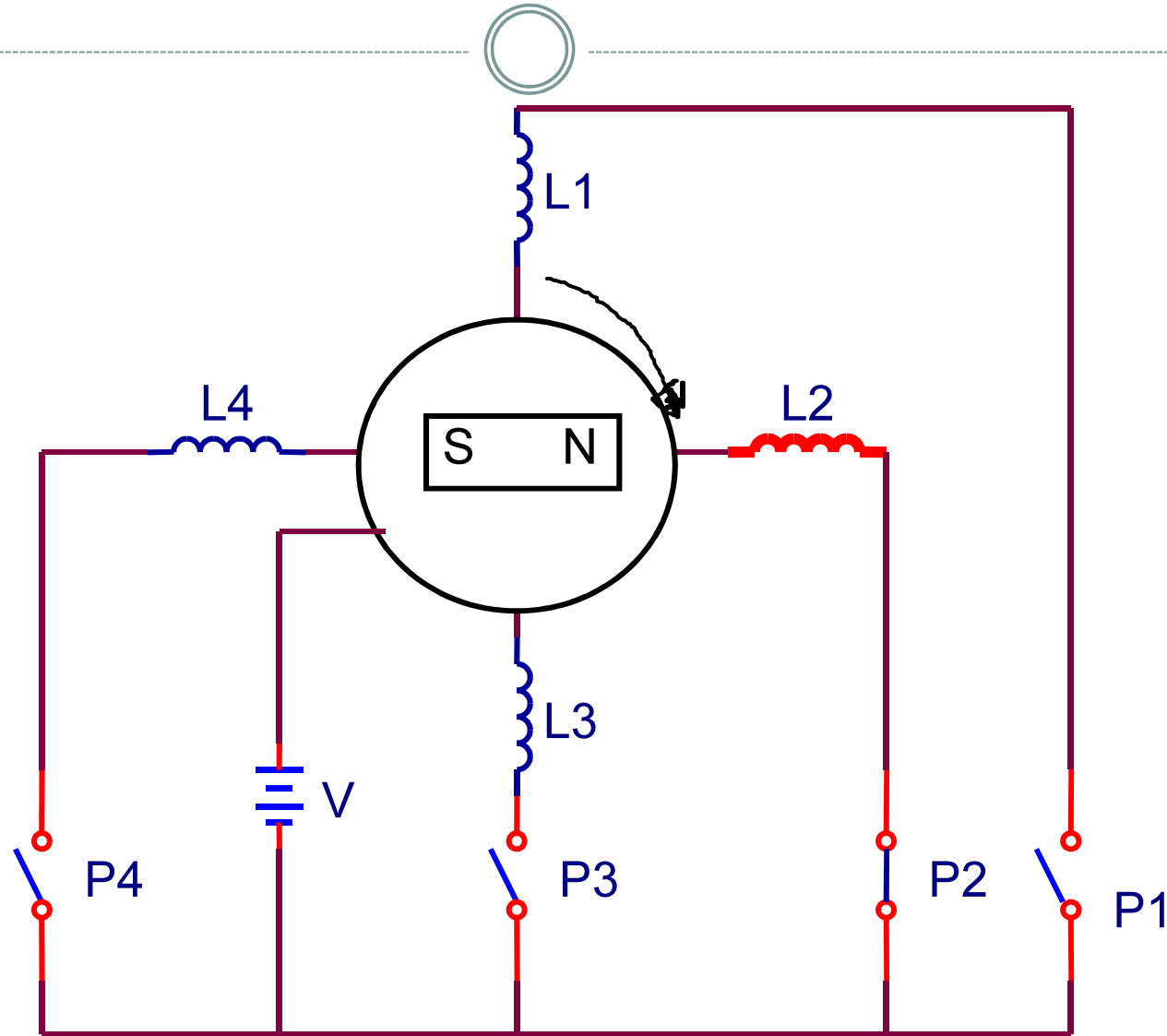



# Realizacija pogonske elektronike pomoću MOSFET prekidača

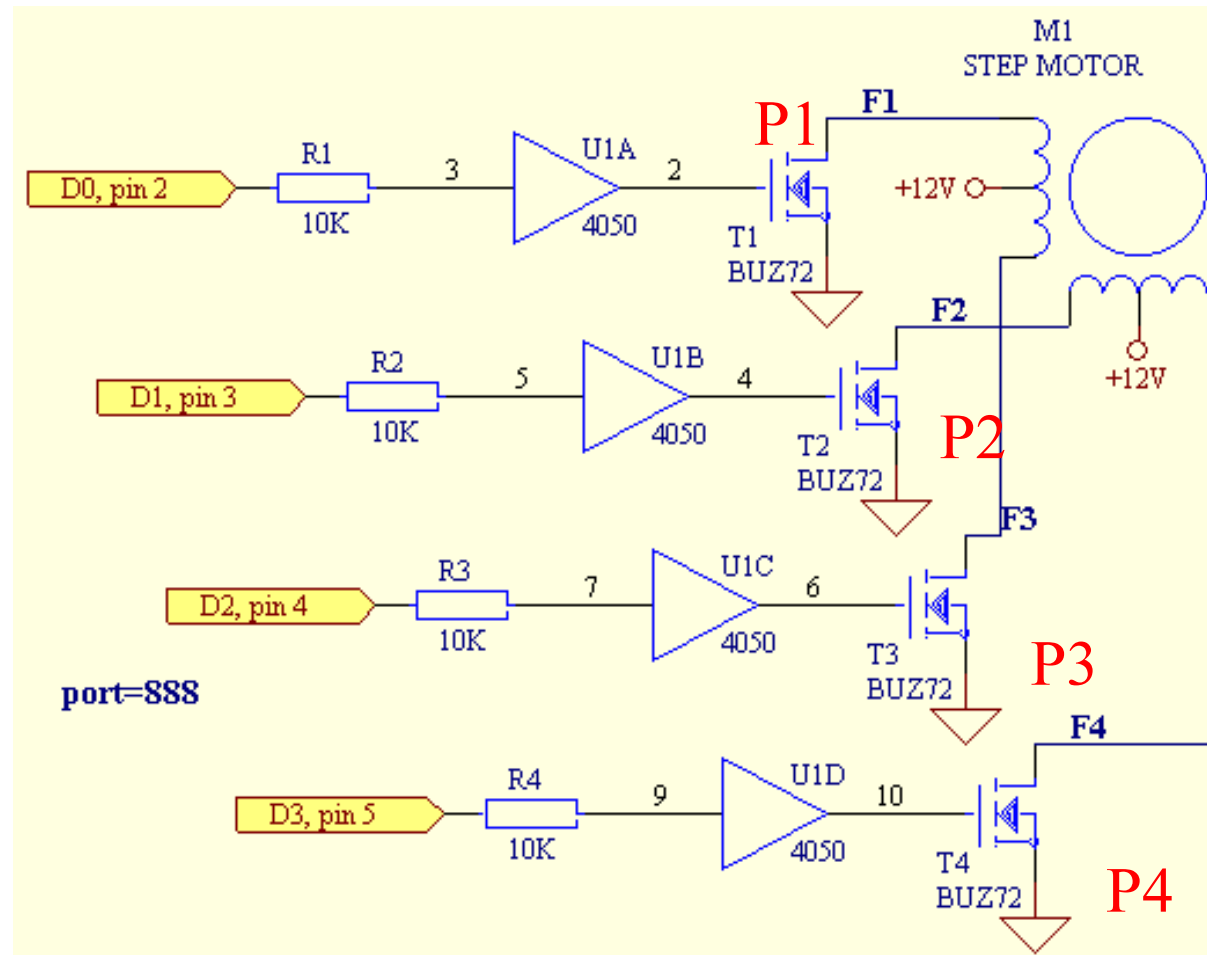

# Unipolarni i bipolarni namotaji

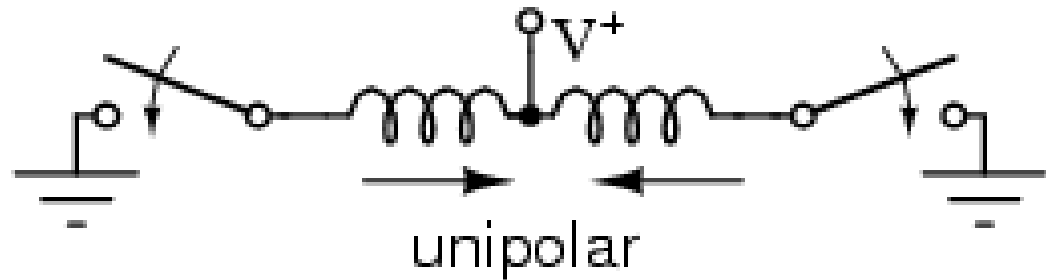
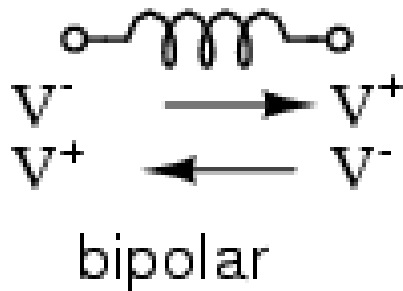

Jedan bipolarni namotaj zamjenjuje 2 unipolarna.  
Međutim, pogon bipolarnog namotaja je komplikovaniji.

Za 4 fazni motor, za pogon sva 4 unipolarna namotaja treba nam 4 (tranzistorskih) prekidača, dok za pogon samo 2 bipolarna namotaja treba nam 8 (tranzistorskih) prekidača.

# Realizacija pogonske elektronike za motore sa 2 bipolarna namotaja

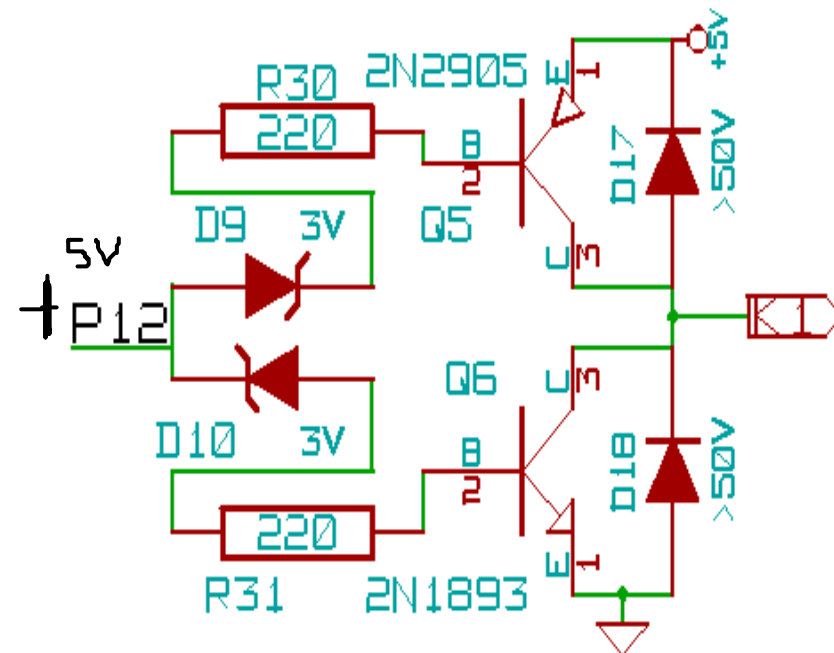
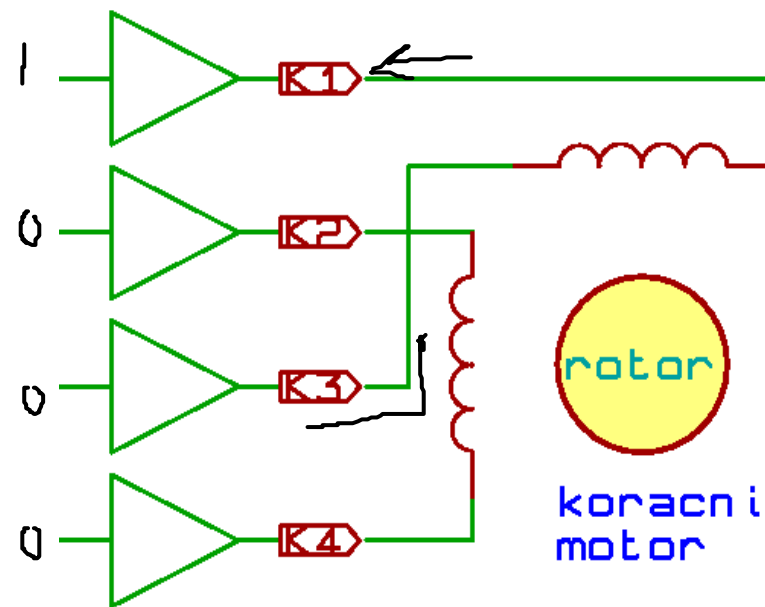

Struja kroz namotaj može biti u jednom ili drugom smjeru.

Zato se sva 4 izlazna stepena prave kao push-pull.

Desno je detaljna šema jednog push-pull izlaznog stepena primjenjenog na maketi.

# KORAČNI MOTOR 28BYJ-48

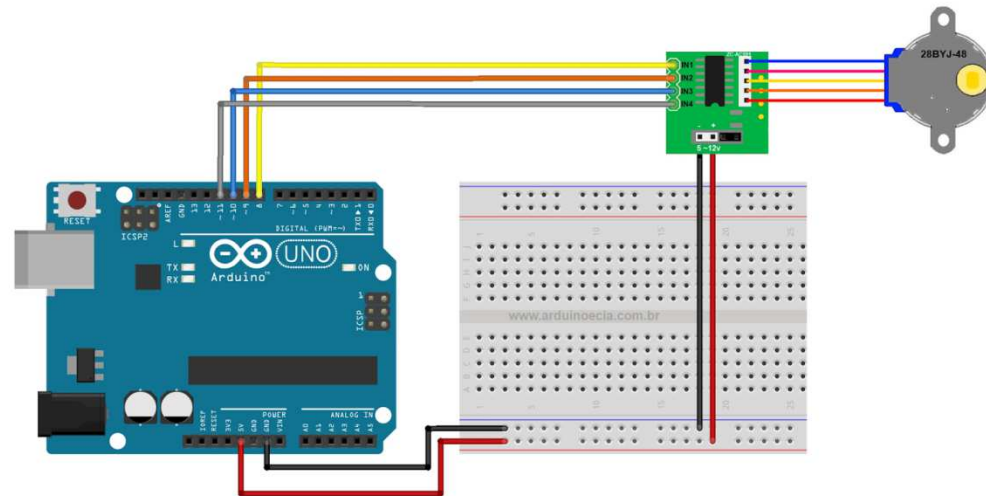
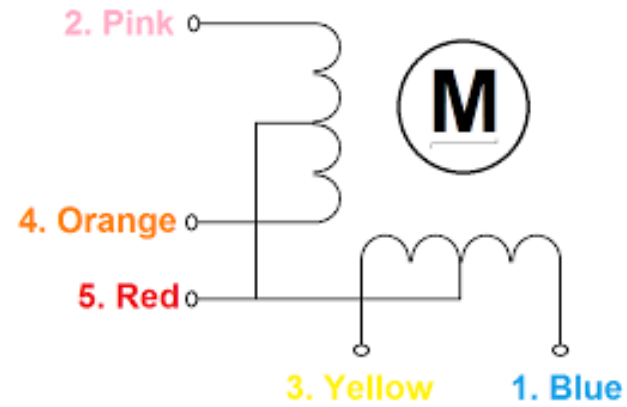

# Realizacija pogonske elektronike pomoću ULN2003A kola

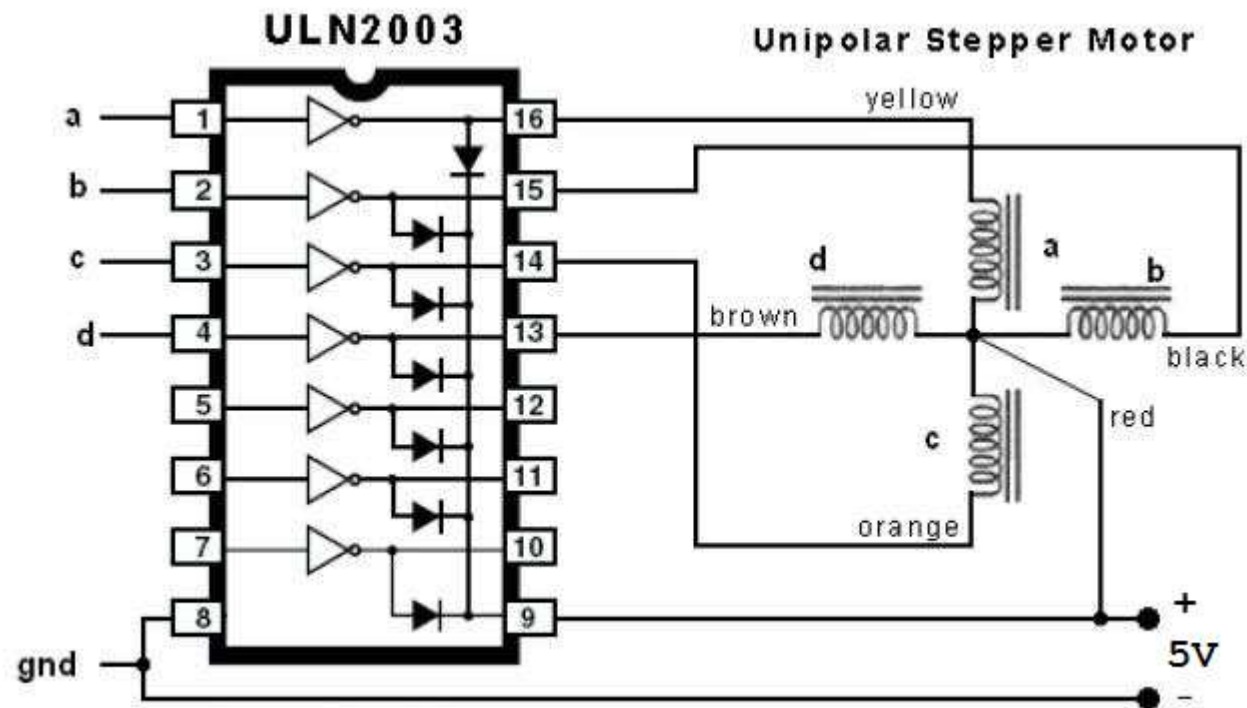



# Funkcionalni blok dijagram ULN2003A kola

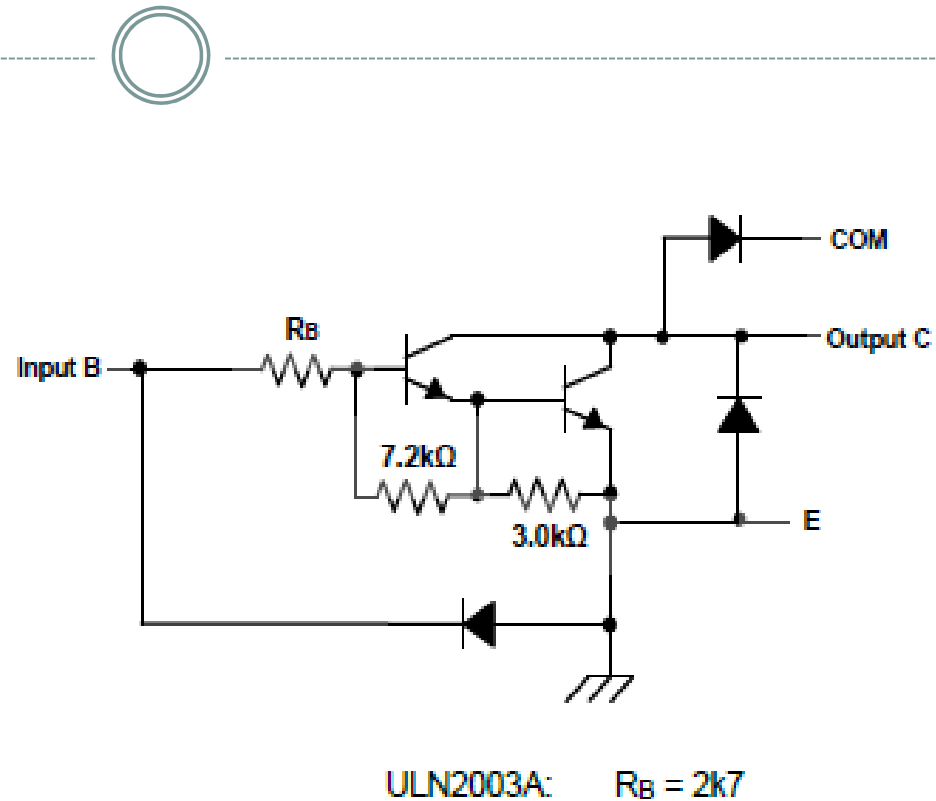
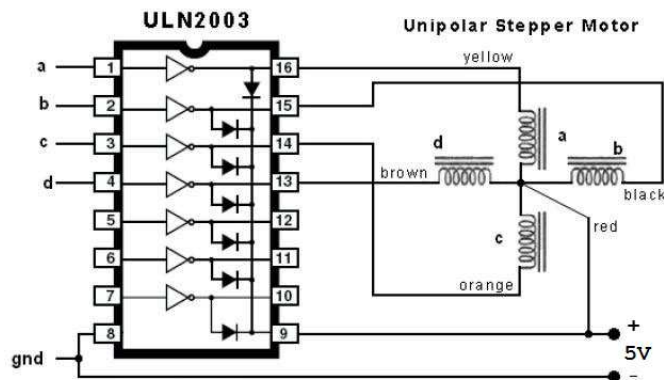

ULN2004A predstavlja Darlington niz. Element niza je Darlington spoj sa zajedničkim emitorom i otvorenim kolektorom.

Svaki element niza je deklarisan za 500mA.

# Načini upravljanja koračnim motorom



- 1. Puni korak**
- 2. Polukorak**
- 3. Mikrokorak**

# Koračanje punim korakom

Korak	Namotaj 1	Namotaj 2	Namotaj 3	Namotaj 4	Slika
P4	0	0	0	1	
P3	0	0	1	0	
P2	0	1	0	0	
P1	1	0	0	0	

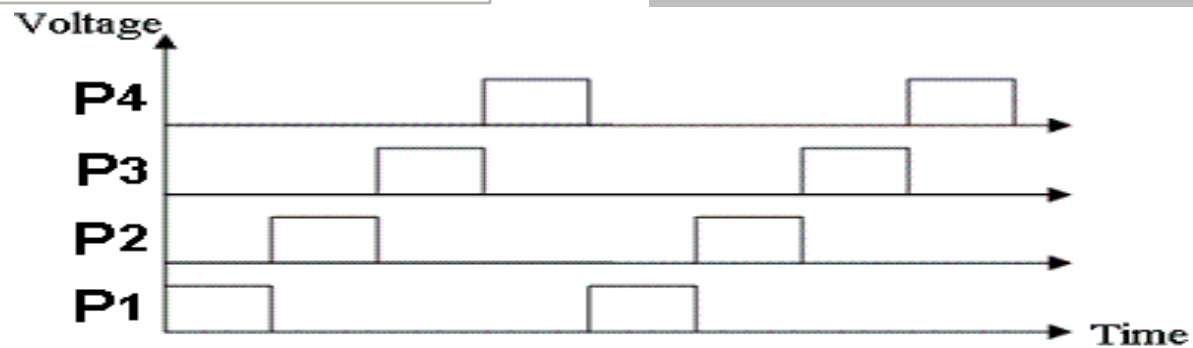

...- P1 - P2 - P3 - P4 - P1 -...  
jedan smjer

...- P1 - P4 - P3 - P2 - P1 -...  
drugi smjer

# Programska podrška za koračanje punim koracima









## 4 koraka

```
PORTB=1;  
Sleep(100);  
PORTB=2;  
Sleep(100);  
PORTB=4;  
Sleep(100);  
PORTB=8;  
Sleep(100);
```

## 100 koraka

```
int korak[]={1,2,4,8}; // definisanje niza  
/* U petlji se odrađuje 1 korak */  
PORTB=korak[i%4];  
  
i++; // za koračanje naprijed  
i--; // za koračanje nazad  
  
// onoliko puta koliko je zadato koraka
```

# Koračanje polukorakom

Korak	Namotaj 1	Namotaj 2	Namotaj 3	Namotaj 4	
P1	1	0	0	0	
P12	1	1	0	0	
P2	0	1	0	0	
P23	0	1	1	0	
P3	0	0	1	0	
P34	0	0	1	1	
P4	0	0	0	1	
P41	1	0	0	1	

-P1 - P12 - P2 - P23 - P3 - P34 - P4 - P41 - P1 -.. jedan smjer

..- P1 - P14 - P4 - P43 - P3 - P32 - P2 - P21 - P1 -.. drugi smjer

P12 – označava da su istovremeno uključeni i P1 i P2,

P23 – označava da se istovremeno uključeni i P2 i P3,

itd.

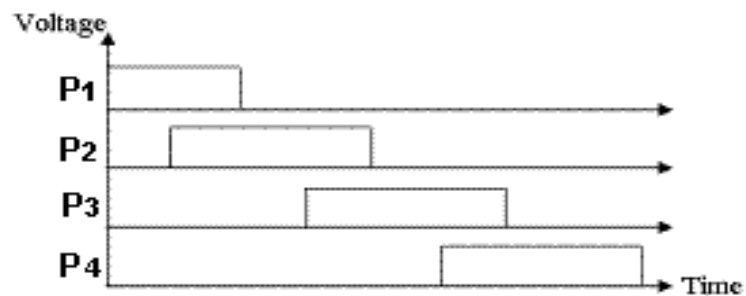



# Programska podrška za koračanje polukoracima

## Prosti primjer

```
PORTB=1;
Sleep(100);
PORTB= 1+2;
Sleep(100);
PORTB= 2;
Sleep(100);
PORTB= 2+4;
Sleep(100);
PORTB= 4;
Sleep(100);
PORTB= 4+8;
...itd...
```

## Napredniji primjer

```
int polukorak[]={1, 1+2, 2, 2+4, 4, 4+8, 8,
8+1}; // definisanje niza

/* U petlji se odrađuje po 1 polukorak */

PORTB=polukorak[i%8];

i++; // za koračanje naprijed
i--; // za koračanje nazad

// onoliko puta koliko je zadato koraka
```

# Koračanje mikrokorakom

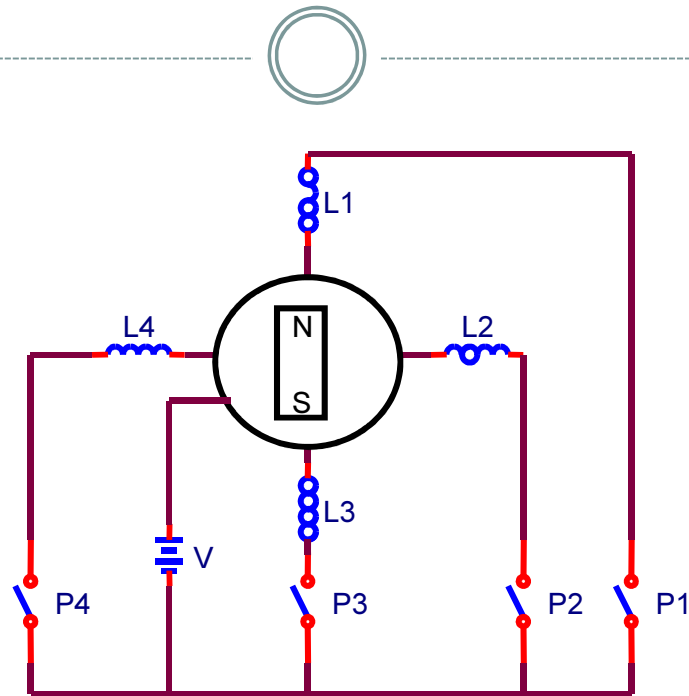

Podešavanjem odnosa struja kroz susjedne namotaje, npr. L1 i L2, može se podešavati ugao zakretanja rotora, t.j. dio koraka. Finoća podešavanja je obično  $1/256$  koraka.

Ukoliko se podese jednake stuje, rotor će se postaviti na pola koraka.

# 3 fazni motor

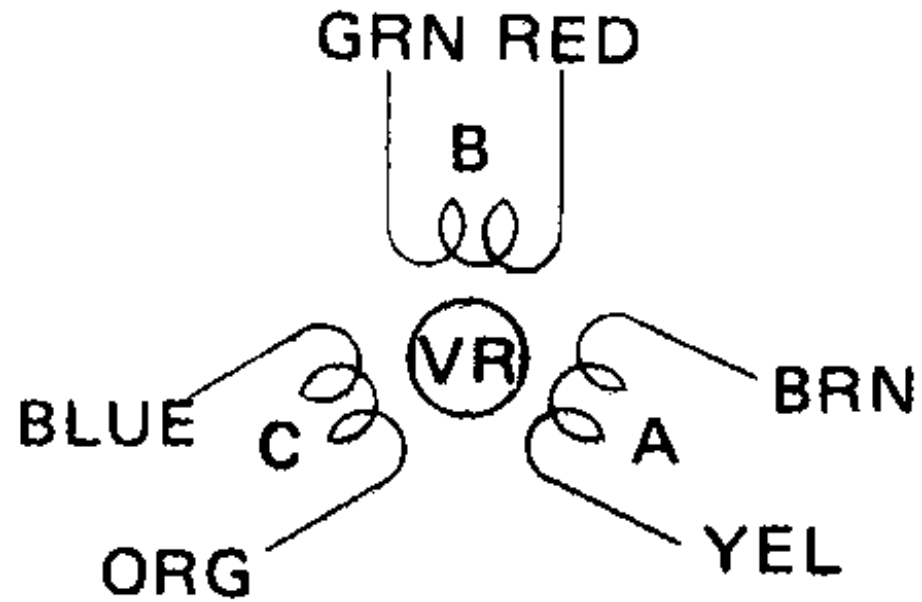

3 phase

# 4 fazni motor

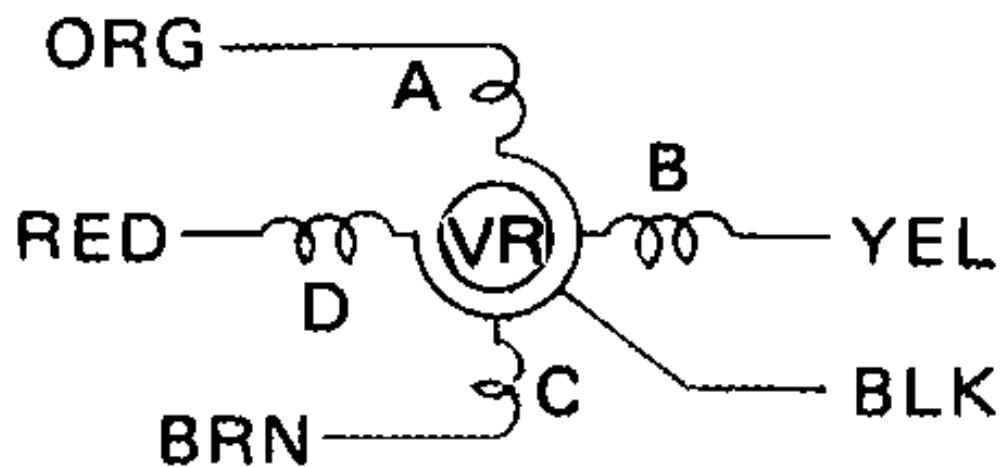

4 phase

# 5 fazni motor

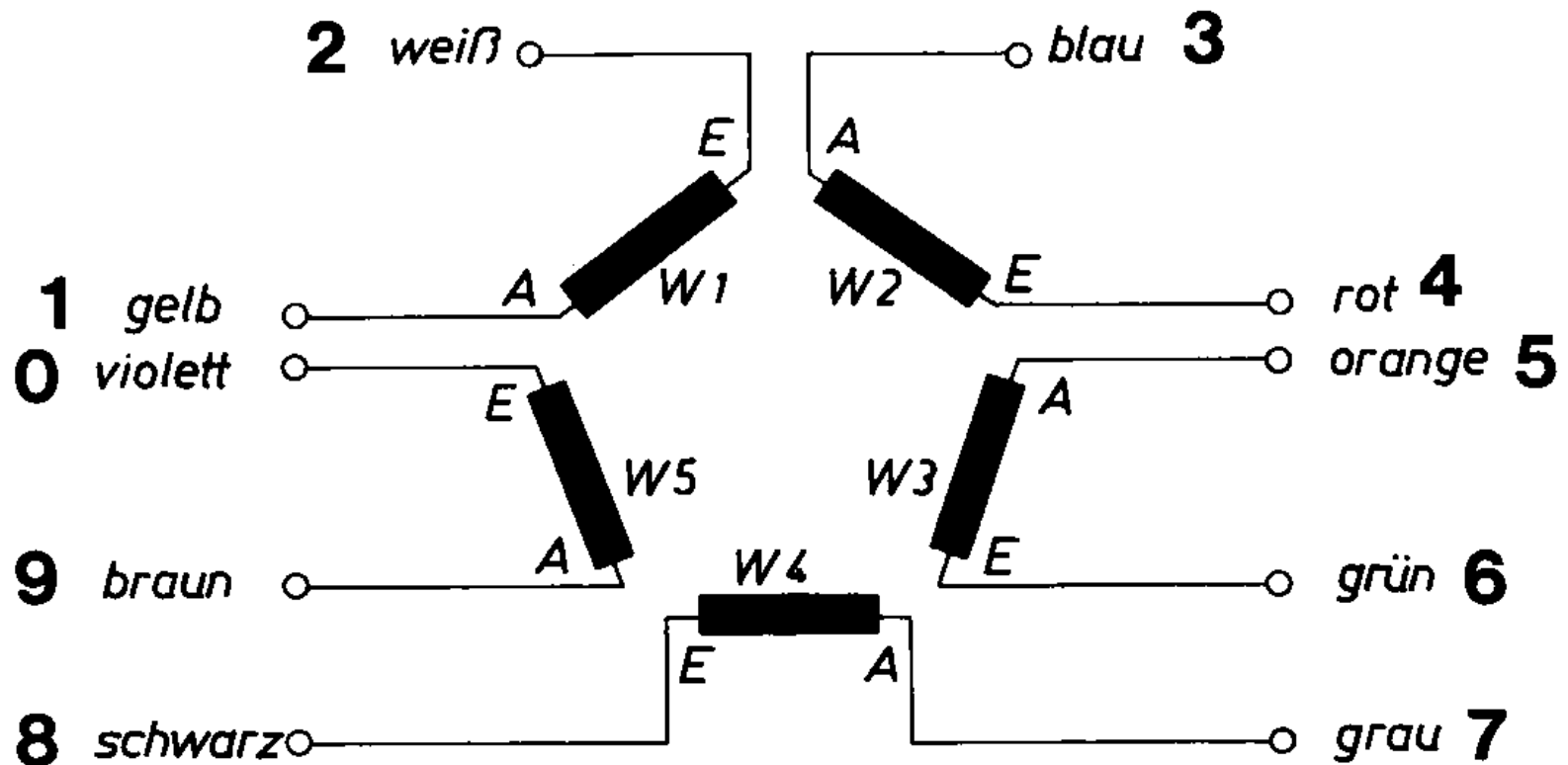



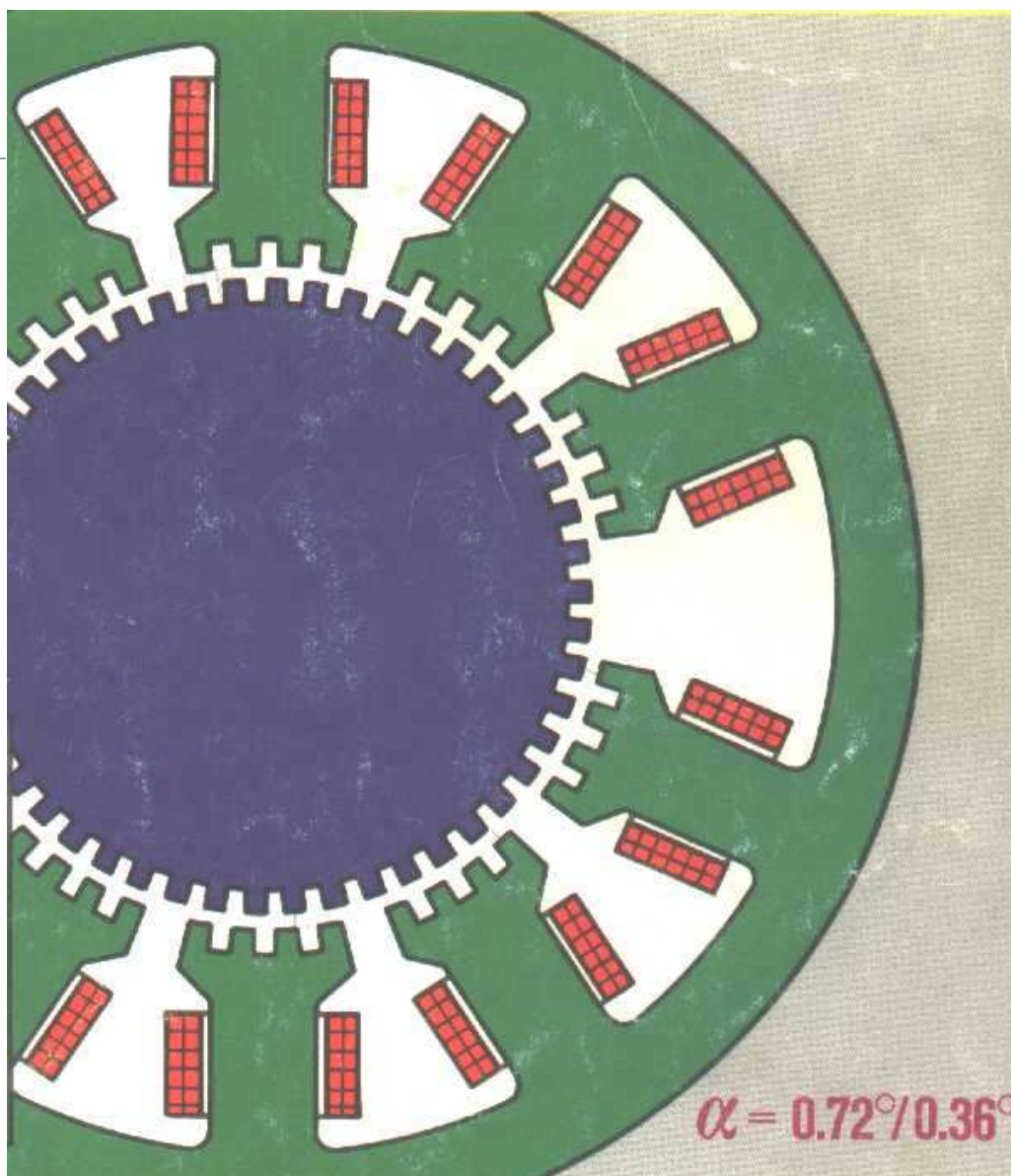

Zupčasta  
struktura  
omogućava  
postizanje  
velikog broja  
koraka po  
punom krugu.

# Zupčasti polovi i rotor



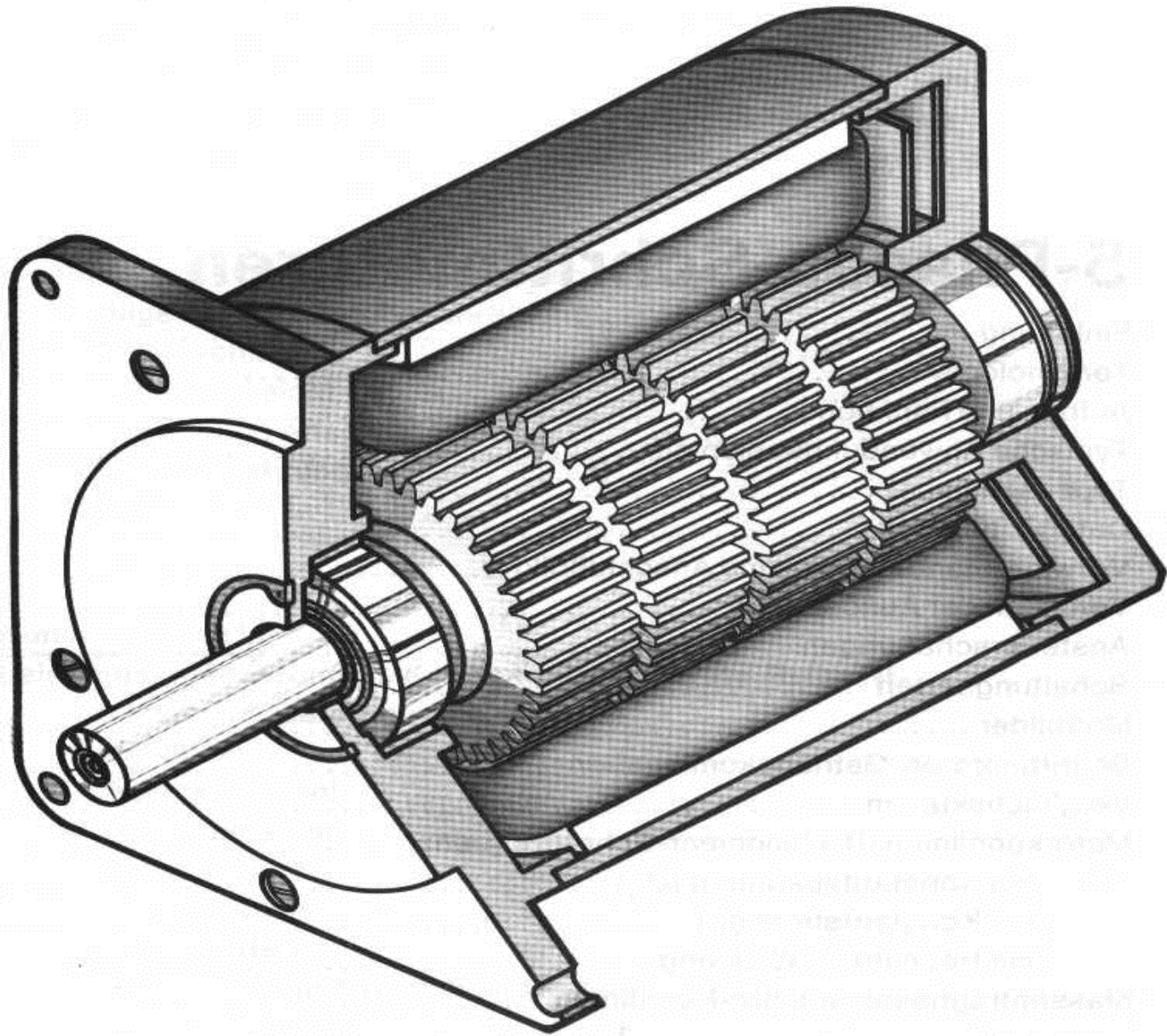

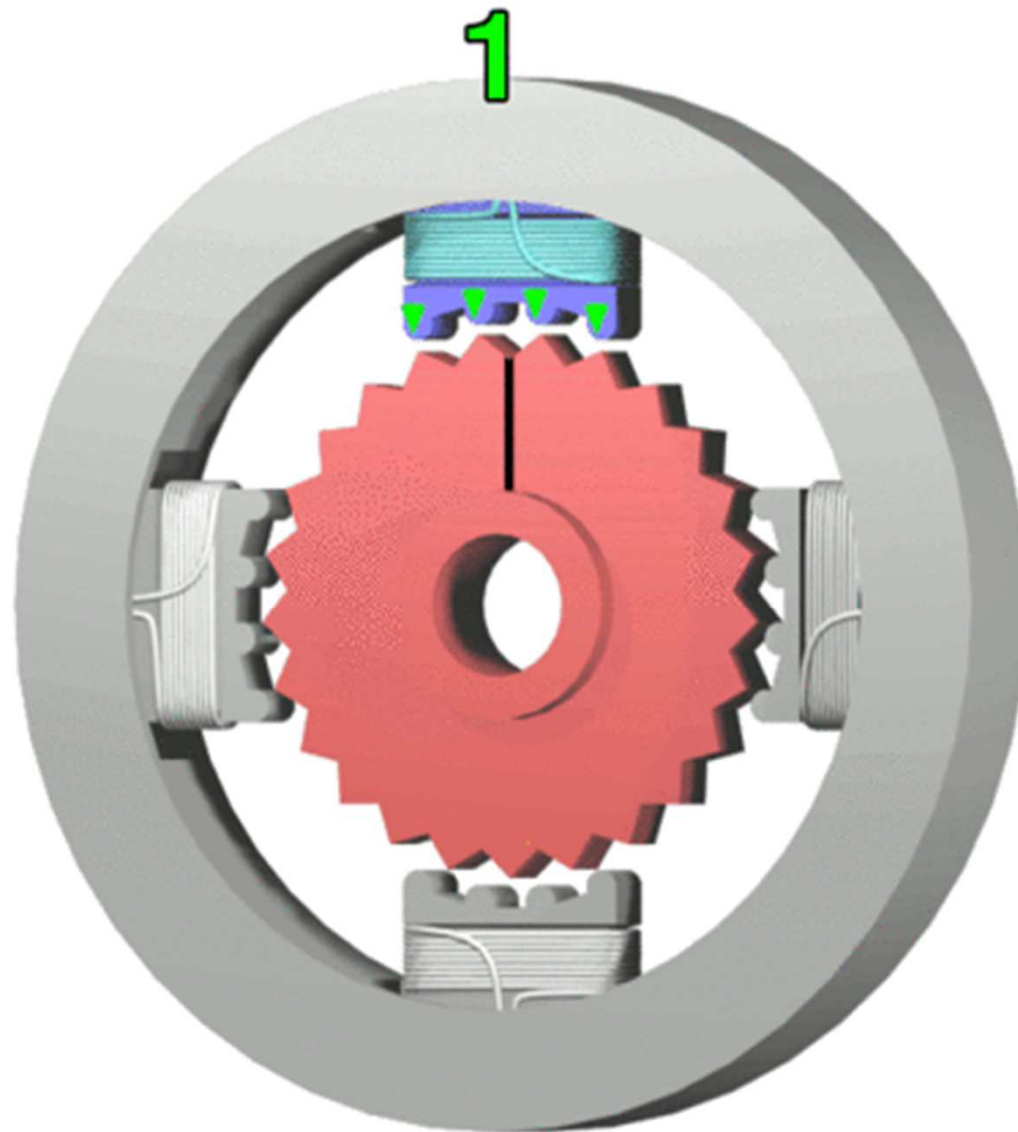

# Pogonske karakteristike

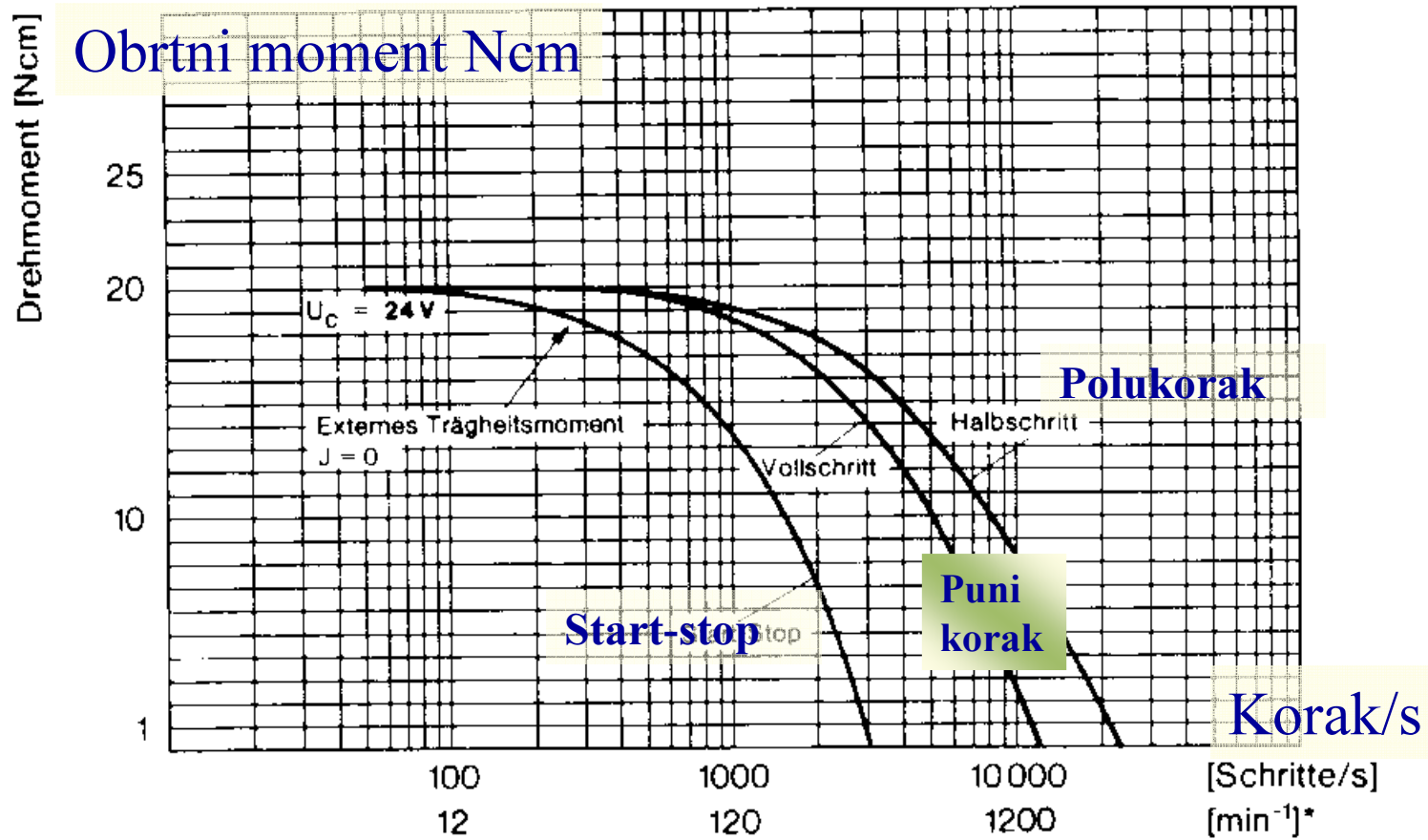



# Unaprijeđeni koračni motor



Koračni motori, zbog diskretnog koračanja, “tresu” više od ostalih motora. Ovaj nedostatak je manje izražen kod višefaznih motora. Može se značajno ublažiti upravljanjem mikrokoracima.

Najnoviji napredak je da se na rotor postavi davač položaja i zatvori povratna sprega po poziciji, čime se praktično dobija JSS motor bez četkica (DC brushless motor). Na ovaj način se dobija optimalni obrtni moment i eliminišu greške preskoka koraka. Radi ukupne jednostavnosti, motor se normalno pogoni kao koračni motor (bez povratne sprege), a samo u zahtjevnim situacijama prelazi se na upravljanje sa povratnom spregom (brushless).

# ZADACI ZA VJEŽBU



1. Odrediti broj koraka na punom krugu koračnog motora. Zaustavljanje motora inicirati pritiskom na taster. Poruke o broju koraka ispisati na serijskom monitoru. Otpuštanjem tastera treba da započne novo brojanje koraka. **(3 boda)**

2. Odrediti maksimalnu brzinu okretanja koračnog motora. Pritiskom na taster, na serijskom monitoru ispisati informaciju o maksimalnoj brzini. Po otpuštanju tastera koračni motor treba da se nastavi okretati maksimalnom brzinom. **(4 boda)**

3. Intezitet spoljašnjeg svjetla određuje brzinu okretanja koračnog motora. Što je intezitet svjetla veći brzina okretanja koračnog motora je manja i obrnuto. Informaciju o intezitetu svjetla i brzini koračnog motora prikazivati na serijskom monitoru. **(5 boda)**