

# FESTO

Process  
Control  
System

Compact  
Workstation  
Manual



Process Control System  
EN  
04/05

## Intended use

This station has been developed and produced solely for vocational and further training purposes in the field of automation and communication. The company undertaking the training and / or the instructors is / are to ensure that trainees observe the safety precautions described in the manuals provided.

Festo Didactic herewith excludes any liability for damage or injury caused to trainees, the training company and / or any third party, which may occur if the system is in use for purposes other than purely for training, unless the said damage / injury has been caused by Festo Didactic deliberately or through gross negligence.

Order No.:

Description: Manual

Designation: PCS Compact Workstation

Status: 04/2005

Authors: Jürgen Helmich, ADIRO

Graphics: Jürgen Helmich, ADIRO

Layout: Jürgen Helmich, ADIRO

© Adiro Automatisierungstechnik GmbH, 73734 Esslingen, Germany, 11/2004

Internet: [www.festo.com/didactic](http://www.festo.com/didactic) <http://www.festo.com/didactic/de/ProcessAutomation>

e-mail: [did@festo.com](mailto:did@festo.com)

The copying, distribution and utilisation of this document as well as the communication of its contents to others without express authorisation of is prohibited. Offenders will be held liable for the payment of damages. All rights reserved, in particular the right to carry out patent, utility model or ornamental design registration.

# Contents

<b>1</b>	<b>Introduction</b>	<b>5</b>
1.1	Training contents	6
1.2	Important notes	7
1.3	Duty of the operating authority	7
1.4	Duty of trainees	7
1.5	Risks involved in dealing with the Compact Workstation	8
1.6	Warranty and liability	9
1.7	Use for intended purpose	9
<b>2</b>	<b>Notes on safety</b>	<b>11</b>
<b>3</b>	<b>Technical data</b>	<b>13</b>
<b>4</b>	<b>Transport / Unpacking / Scope of delivery</b>	<b>15</b>
<b>5</b>	<b>Design and function</b>	<b>17</b>
5.1	Pump	20
5.2	Process drive with ball valve	21
5.3	Level monitoring	22
5.4	Proportional valve	25
5.5	Level control function	26
5.6	Flow rate control function	27
5.7	Pressure control function	29
5.8	Temperature control system	31
<b>6</b>	<b>Commissioning</b>	<b>33</b>
6.1	Workstation	33
6.2	Visual check	33
6.3	Cable connections	34
6.4	Pneumatic connection	36
6.5	Voltage supply	36
6.6	Choosing controlled system	36
6.7	Loading the PLC program	38
6.8	Filling and deaeration	39
6.9	Commissioning sequence Compact Workstation	40
6.10	Start sequence	41
6.11	Notice	42
<b>7</b>	<b>Maintenance</b>	<b>43</b>
<b>8</b>	<b>Appendix</b>	<b>45</b>
	Allocation list	47

Contents

# 1 Introduction

The Festo Didactic Learning System for Automation is designed to meet a number of different training and vocational requirements. The systems and stations of the Compact Workstation facilitate industry-orientated vocational and further training and the hardware consists of didactically suitable industrial components.

The Compact Workstation station provides you with an appropriate system for practice-orientated tuition of the following key qualifications

- Social competence,
- Technical competence and
- Methodological competence

Moreover, training can be provided to instill team spirit, willingness to cooperate and organisational skills.

Actual project phases can be taught by means of training projects, such as:

- Planning,
- Assembly,
- Programming,
- Commissioning,
- Operation,
- Maintenance and
- Fault finding.

**1.1  
Training contents**

Training contents covering the following subjects can be taught:

- Mechanics
  - Mechanical construction of a station
- Process Engineering
  - Reading and drawing flow charts and dokumentation
- Pneumatics
  - Piping connections of pneumatic components
- Electrical technology
  - Correct wiring of electrical components
- Sensors
  - Correct use of sensors
  - Measuring of non-electrical, process and control variables
- PLC
  - Programming and use of a PLC
  - Programming of alternative (OR) branches
  - Fieldbus technology
- Closed-loop control technology
  - basics of closed-loop control technology
  - Extension of measuring chains into closed control loops
  - Analyze a closed-loop system
  - P, I, D-control
  - Optimize a closed-loop system
- Closed-loop controller
  - Configuration, assigning operation parameters and optimization of a closed-loop controller
- Commissioning
  - Commissioning of a closed-loop system
  - Commissioning of a process engineering system
- Fault finding
  - Systematic fault finding on a process engineering system
  - Examination and mantainence of a process engineering system
  - Operation and observation of a process

**Topics for project work**

- Selection of electrical components
  - level sensor
- Savety check of a tank
  - how to use a float sensor

**1.2  
Important notes**

The basic requirement for safe use and trouble-free operation of the Compact Workstation is to observe the fundamental safety recommendations and regulations.

These operating instructions contain important notes concerning the safe operation of the Compact Workstation.

The safety recommendations in particular must be observed by anyone working on the Compact Workstation.

Furthermore, the rules and regulations for the prevention of accidents applicable to the place of use must be observed.

**1.3  
Duty of the operating  
authority**

The operating authority undertakes to ensure that the Compact Workstation is used only by persons who:

- are familiar with the basic regulations regarding operational safety and accident prevention and who have received instructions in the handling of the Compact Workstation,
- have read and understood the chapter on safety and the cautionary notes in these operating instructions and confirmed this by signing,
- are regularly vetted to ensure safe working.

**1.4  
Duty of trainees**

Prior to commencing work, all persons assigned to working on the Compact Workstation have a duty to:

- observe the basic regulations regarding operational safety and the prevention of accidents,
- read the chapter on safety and the cautionary notes in these operating instructions and to confirm that they have understood these by signing.

**1.5  
Risks involved in dealing  
with the Compact  
Workstation**

The Compact Workstation is designed according to state of the art technology and in compliance with recognised safety regulations. However when using the system there is nevertheless a risk of physical or fatal injury to the user or third parties or of damage being caused to the machinery or other material assets.

The Compact Workstation is to be used only:

- for its intended purpose and
- in an absolutely safe conditions.



**Faults impairing safety must be rectified immediately!**



**1.6  
Warranty and liability**

In principle all of our „Terms and Conditions of Sale“ apply. These are available to the operating authority upon conclusion of the contract at the latest. Warranty and liability claims for persons or material damage are excluded if these can be traced back to one or several of the following causes

- Use of the machine not in accordance with its intended purpose
- Incorrect assembly, commissioning, operation and maintenance of the machine
- Operation of the machine using faulty safety equipment or incorrectly fitted or non operational safety or protective devices
- Non observance of notes in the operating instructions regarding transport, storage, assembly, commissioning, operation, maintenance and setting up of the machine
- Unlawful constructional modifications on the machine
- Inadequate monitoring of machine components subject to wear
- Incorrectly carried out repairs
- Catastrophes as a result of foreign objects and acts of force major.

Festo Didactic herewith rules out any liability for damage or injury to trainees, the training company and /or other third parties which may occur during the use / operation of the system other than purely in a training situation, unless such damage has been caused intentionally or due to gross negligence by Festo Didactic.

**1.7  
Use for intended purpose**

This system has been developed and produced exclusively for vocational and further training in the field of automation and communication. The training authority and / or the instructors is / are to ensure that trainees observe the safety precautions described in the manual provided.

The use of the system for its intended purpose also includes:

- following all advice in the operating instructions and
- carrying out inspection and maintenance work.



## 2 Notes on safety



### General

- Trainees must only work on the station under the supervision of an instructor.
- Observe the data in the data sheets for the individual components, in particular all notes on safety!

### Electrics

- Electrical connections are to be wired up or disconnected only when power is disconnected!
- Use only low voltages of up to 24 V DC.

### Pneumatics

- Do not exceed the permissible pressure of 8 bar (800 kPa).
- Do not switch on compressed air until you have established and secured all tubing connections.
- Do not disconnect air lines under pressure.
- Particular care is to be taken when switching on the compressed air. Cylinders may advance or retract as soon as the compressed air is switched on.

### Mechanics

- Securely mount all components on the plate.
- No manual intervention unless the machine is at rest.
- The pump can be mounted horizontally or vertically. If mounted, the output of the pump must point upwards. The pump must be mounted so that it is flooded (see also data sheet).

**Process engineering**

- Before filling the tanks with water switch of power supply!  
Switch of power supply 24 VDC and 230 VAC (110 VAC)!
- The use of tap water in quality of drinking water (recommended), ensures a prolonged maintenance-free operation of the system (proportional valve and pump).
- The maximum operating temperature of the tanks must not exceed +65 °C.
- Do not operate the heating unit unless the heating element is fully immersed in fluid.
- Do not operate the piping system with a system pressure higher than 0,5 bar.
- Do not operate the pump without fluid, running dry or used for sea water or contaminated fluids.
- Please empty fluids from the system (tanks, piping, close valves) before you make changes at the piping system.
- It is possible to drain the fluids inside the Compact Workstation by opening hand valve V105

### 3 Technical data

Parameter		Value
max. operating pressure piping system		50 kPa (0.5 bar)
power supply for station		24 V DC
profile plate		7000 x 700 x 32 mm
(volumetric) flow rate of the pump		10 l/min
tank volume		12 l max.
flexible piping system		DN15 ( $\varnothing_a$ 15mm)
digital inputs		7
digital outputs		5
analog inputs		4
analog outputs		2
amount of tanks		3
output range control element	pump (0...24 VDC)	voltage 0...10 V
	2/2W-proportional valve	voltage 0...10 V
	heating element 230 VAC (power 1000 W)	On/Off (control relay 24 VDC)
working range closed-loop system for level control		0...350 mm
measuring range level sensor		50...300 mm
signal range level sensor		current 4...20 mA
working range closed-loop system for flow rate control		0...7 l/min
measuring range flow sensor		0,3...9,0 l/min
signal range flow sensor		frequency 0...1200 Hz
working range closed-loop system for pressure control		0...30 kPa (0...300 mbar)
measuring range pressure sensor		0...10 kPa (0...100 mbar)
signal range pressure sensor		voltage 0...10 V
working range closed-loop system for temperature control		0...60° C
measuring range temperature sensor		-50° C...+150° C
signal range temperature sensor		resistance PT100

Technical data

## 4 Transport / Unpacking / Scope of delivery

### **Transport**

The Compact Workstation is delivered in a container with a pallet base.

The container must be transported on a suitable fork lift truck at all times and must be secured against tipping or falling off.

The carrier and Festo Didactic are to be notified immediately of any damage caused during transport.

### **Unpacking**

Carefully remove the padding material in the container box when unpacking the station. When unpacking the station, make sure that none of the station assemblies have been damaged.

Check the station for any possible damaged once unpacked. The carrier and Festo Didactic are to be notified immediately of any damage.

### **Scope of delivery**

Check the scope of delivery against the delivery note and the order. Festo Didactic must be notified immediately of any discrepancies.





## 5 Design and function



Compact Workstation

The Compact Workstation combines 4 closed-loops with digital and analog sensors and actuators. With a PLC or a controller it is possible to use them individually or cascaded:

- level controlled system
- flow rate controlled system
- pressure controlled system
- temperature controlled system

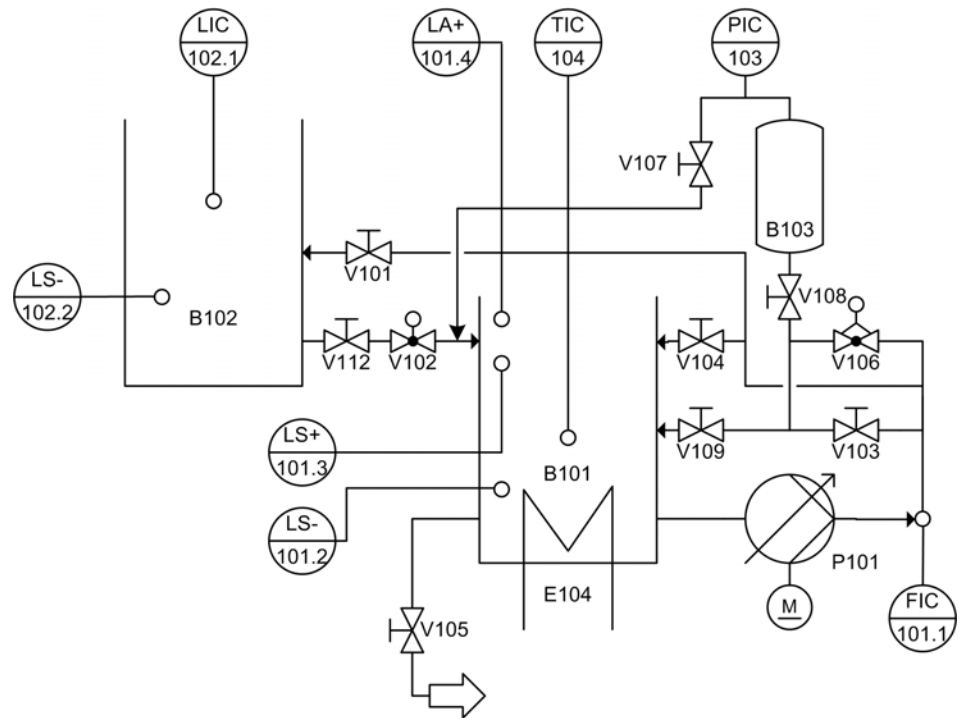

Flow chart Compact Workstation (DIN 19227)

It is possible to work with following functions by using the 4 closed-loop systems:

- two point control of a level control system with a analog standard signal
- continuous control of a level control system with a analog standard signal
- continuous control of a flow rate control system with a pump as controlled system and a impulse signal for frequency measuring
- continuous control of a flow rate control system with a proportional valve (controlled system) and a impulse signal for frequency measuring
- continuous control of a flow rate control system with a pump as controlled system and with a analog standard signal
- continuous control of a flow rate control system with a proportional valve as controlled system and with a analog standard signal
- continuous control of a pressure control system with a pump as controlled system and with a analog standard signal
- continuous control of a pressure control system with a proportional valve as controlled system and with a analog standard signal
- two point control of a temperature control system with a analog standard signal

The basic components of the Compact Workstation are:

- Analog ultrasonic sensor
- Flow sensor with frequency signal
- Pressure sensor, piezoresistive
- Pressure gauge for 0...1bar
- PT100 temperature sensor
- 2x Capacitive proximity switch for min/max level in lower tank
- Float switch for threshold function (electromechanical) in upper tank
- Float switch for overflow alarm monitoring in lower tank
- Centrifugal pump
- Motor Controller for pump
- Proportional valve with electronic control module
- Heating system with integrated control relay
- Process ball valve consisting of pneumatic rotary drive (SYPAR) with sensor box
- I/O Terminal
- Terminal for analog signals
- Signal converter: current to voltage, frequency to voltage, PT100 to voltage
- PLC or closed-loop controller
- control panel
- Piping system incl. 4 transparent segments
- Pressure tank (reactor)
- Water tanks
- Manual valve
- Manual ball valve for drain
- Service Unit
- ER mounting frame

The functions of each closed-loop system result in the specified combination of the (manual-) valves. Also they depend on the programming, configuration or parametrizing of the PLC/ controlling system.

### 5.1 Pump

The centrifugal pump P101 (1) is the controlling equipment used in all controlled systems. The pump is delivering fluid from a reservoir tank B101 through the piping system.



Controlling equipment - Pump P101 (1)

The pump must not be operated running dry. Before commissioning the reservoir tank or piping system to/from the pump should be filled with fluid.

The pump is driven by the motor controller A4 and relay K1. With a digital output (O2 at XMA1) it is possible to switch from digital binary control to analog control variable from 0 to 24 V. At digital binary control (O2 = 0) the pump is turn on/off with a additional output (O3 at XMA1). At analog control (O2 = 1) the drive voltage from analog output signal channel 0 (UA1 at X2) is setting the speed of the pump from 0 to 10 V.



Please also see the data sheet of the pump for further safety instructions!

## 5.2 Process drive with ball valve

The fitting V102 is opened and closed by a pneumatical process drive. The controlled equipment consists of a brass ball valve (1) with rotary drive type SYPAR (4), using scotch yoke principle. A solenoid (2) 5/2 way valve (3) with port pattern to NAMUR and sensor box (5) are flange mounted onto the rotary drive. The flow of the fluid from upper tank B102 into the lower tank B101 is controlled with the ball valve of the process drive.

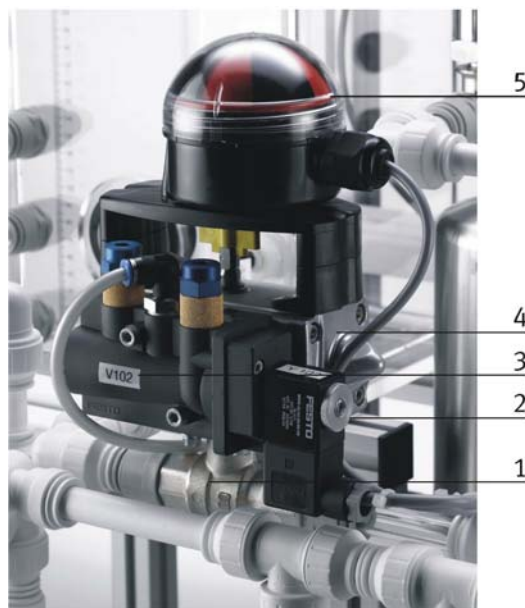

Fitting V102 – pneumatical process drive with ball valve

Key	1	brass ball valve
	2	solenoid
	3	5/2 way valve with port pattern to NAMUR
	4	rotary drive type SYPAR, scotch yoke principle
	5	sensor box

The end position sensing attachment (5) consists of two electrical micro switches with roller lever. The two binary 24 VDC signals (S115 and S116) are connected as inputs to the I/O-terminal XMA1. There is also a visual indication of the drive position for the operator.

### 5.3 Level monitoring

Following technical examples for level monitoring are integrated into the Compact Workstation:

- proximity switches
- float switch for overflow safety
- float switch for threshold function

#### Proximity switches

Two capacitive proximity switches B113 (1) and B114 (2) are located on the back of the lower tank B101 and mounted on a profile plate. The proximity switches can be mechanically adjusted. The sensing distance through the tank wall can be adjusted with a screw. The binary 24 V input signals are connected to the I/O-terminal XMA1.

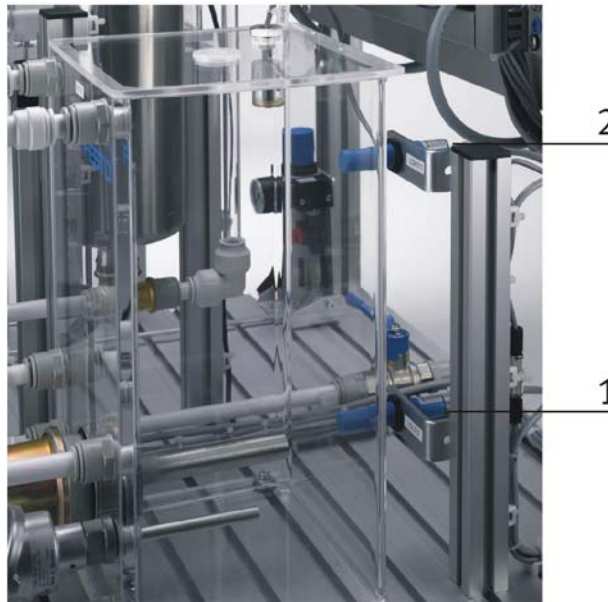

#### Level monitoring with capacitive proximity switches B113 and B114

The minimum level of the tank B101 is indicated by the lower sensor B113. At minimum level the heating element E104 should be totally immersed into the liquid.

The maximum level of the tank B101 is indicated by the upper sensor B114.

At reset position of the system both sensors have to be activated.

## Design and function

### Overflow safety

The overflow at tank B101 is monitored with float switch S111 (1). If the level in the tank exceeds the maximum level the transparent float cylinder is pushed upward. Inside the float cylinder are magnets which activate a reed contact.



### Level monitoring with float switch for overflow safety S111

The binary 24 V input signals (no) is connected to the I/O-terminal XMA1. The signal of the overflow switch should activate a alarm function in the PLC-program and has effect on ball valve V102 and pump P101.

If changed electrically the overflow switch also can be used to turn off the pump or valve with a relay circuit or for signal indication to a emergency relay.

## Design and function

### Threshold function

The increasing fluid level into the upper tank B102 is monitored at a certain minimum level by float switch S112 (1). If the mounting position is changed the switch can also indicate the decreasing level.



### Level monitoring with float switch for threshold function S112

The binary 24 V input signals (nc) is connected to the I/O-terminal XMA1. The cable of the switch has a plug connection for easy connect/disconnect on changing the mounting position.



## Design and function

Switch-on protection for heating

The float switch is monitoring the decreasing filling level in tank. It avoids continuing heating if filling level undershoots the critical point. The heating must be surrounded completely by the fluid.



Float switch as switch-on protection for heating

The cable of the switch has a plug connection and is connected directly to the heating and to the connecting cable for the I/O- connecting board.



#### 5.4 Proportional valve

The proportional valve V106 (1) is a directly actuated 2/2-way valve for flow control of fluids. It can be used as an adjustable remote element in open- or closed-loops. The valve pistons lift off its seat as a function of the solenoid coil current and releases the flow through the valve.

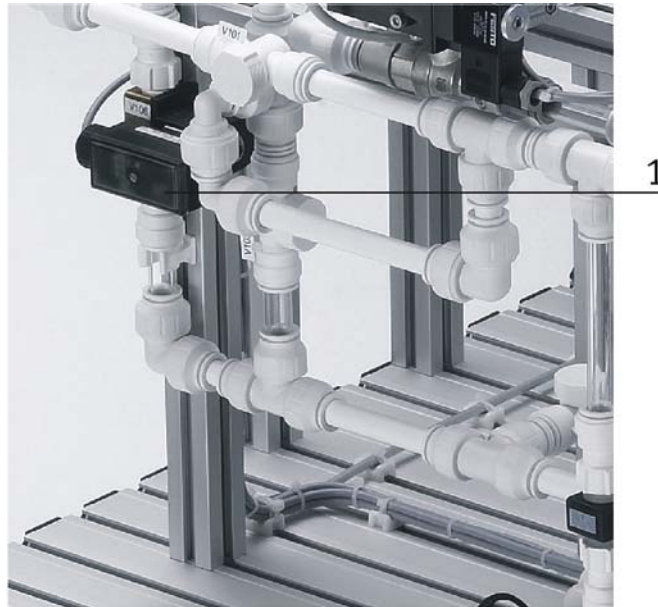

#### Controlling element proportional valve V106

The control electronic of the proportional valve is activated with a binary output (O4 at XMA1). A analog signal from channel 1 (UA2 at X2) is driving the signal input of the proportional valve with a standard analog signal from 0 to 10 V.

The standard analog signal is transformed into a pulse-width modulation (PWM) and the opening of the valve is infinitely adjustable. The frequency of the PWM can be adapted for different valve types.

**5.5**  
**Level control function**

The function of the level controlled system is to regulate the filling level of a fluid in a reservoir tank.

The controlled filling level system can be used as an I or PT1 controlled system.

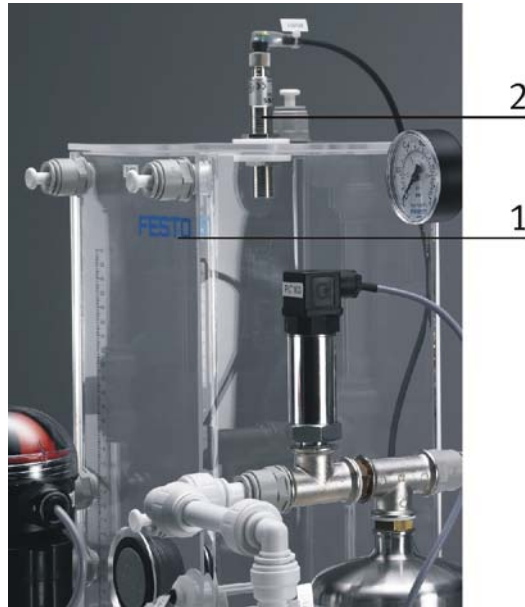

Controlled level system – upper container B102 with ultrasonic sensor B101 (measuring point LIC102)

The pump P101 delivers a fluid from a storage tank B101 to a reservoir tank B102 (1) via a piping system. The level of the fluid inside tank B102 is monitored with an analog ultrasonic sensor B101 (2) at measuring point LIC 102 and read as actual value. The actual value should be kept on a certain level also if disturbances or set point changes occur. For function and characteristic curve of the ultrasonic sensor please see data sheet.

The fluid quantity of the pump P101 is the manipulated value. For controlling system a two-position or a continuous element can be used (see also EMCS block diagrams).

For disturbance is it possible to partly or totally open/close the ball valve V102 to drain the upper into the lower tank or open/close hand valve V104.

The analog current signal (4...20 mA) of the ultrasonic sensor is connected as a standard signal to analog terminal X2 (IE1) as channel 0. The current signal is connected to the measuring transformer A1, too. The transformer changes the analog current signal into a standard voltage signal (0...10 V). The standard voltage signal is also connected to the analog terminal X2 (UE1).

## 5.6 Flow rate control function

In a piping system or a filter unit the flow velocity of a fluid shall be regulated.

The system used is a controlled system with self-regulation (P-controlled system). It does not have a time delay. The control loop in combination with the pump (PT1 behaviour) creates a easily controllable system.



Controlled flow rate system – pump P101 with flow sensor B102 (measuring point FIC 101)

The pump delivers a fluid from the reservoir via a piping system. The flow rate is detected by means of an optoelectronic vane sensor B102 (2) in the form of an actual value. The actual value should be kept on a certain flow rate also if disturbances or set point changes occur.

For controlling system a continuous element can be used (see also EMCS block diagrams). There are two operation modes:

- flow rate control by the means of the pump P101 as controlled system. Manipulated value is the voltage of the pump, which sets the revolution speed.
- flow rate control by the means of the proportional valve V106 as controlled system. Manipulated value is the voltage of the valve coil, which sets the stroke of the valve piston. The pump P101 is running with a constant revolution speed.

For disturbance is it possible to partly or totally open/close the hand valve V104.

A steady square wave signal of the flow rate sensor is connected to a binary input at I/O terminal XMA1 (I0).

Please see the manual of the PLC for maximum input frequency of binary inputs.

The signal level is depending on the applied supply voltage (8...24 V). The pulse signal can be processed with a PLC with integrated counter inputs. The frequency signal is connected to the measuring transformer A2, too. The transformer changes the frequency signal into a standard voltage signal (0...10 V). The standard voltage signal is also connected to the analog terminal X2 (UE2).

**5.7**  
**Pressure control function**

The process pressure of a fluid inside a pressure tank shall be regulated.

The controlled pressure system used is a controlled system with self-regulation (PT1-controlled system). Because the pressure tank is partly filled with gas (air) it is a energy storage system.

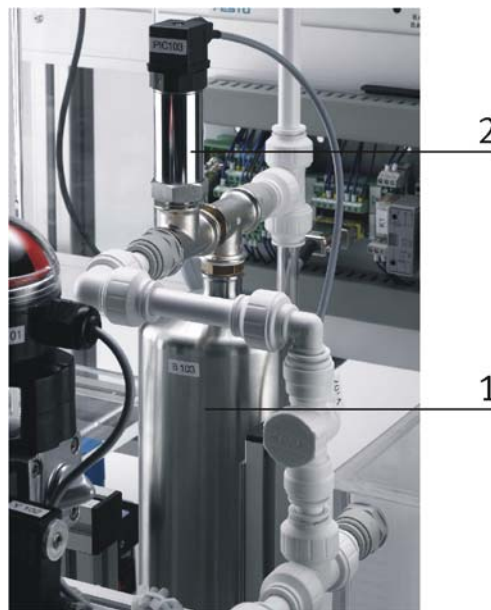

Controlled pressure system – pressure tank B103 with pressure sensor B103 (measuring point PIC 103)

Via a piping system, the pump P101 delivers a fluid from a reservoir into a gas-filled pressure tank B103 (1). The pressure of the gas (air) in the pressure tank is detected by means of a piezoresistive relative pressure sensor in the form of an actual value. The actual value should be kept on a certain pressure also if disturbances or set point changes occur.

**Setup for controlling**

As controlling system a continuous element can be used (see also EMCS block diagrams). During control a pressure is build up and controlled from liquid to gaseous medium in the pressure container B103. The amount of liquid inside of the pressure tank can be increased by opening/closing of the exhaust valve V107 if the pump P101 is running before using closed-loop control. It is recommended to setup the water level of the pressure tank at half level with V107 for a optimal work range during closed-loop control.

There are two operation modes:

- pressure control by the means of the pump P101 as controlled system. Manipulated value is the voltage of the pump, which sets the revolution speed.
- pressure control by the means of the proportional valve V106 as controlled system. Manipulated value is the voltage of the valve coil, which sets the stroke of the valve piston. The pump P101 is running with a constant revolution speed.

For disturbance is it possible to partly or totally open/close the hand valve V109.

The standard voltage signal is also connected to the analog terminal X2 (UE3). Additionally the tank pressure can be read with a pressure gauge.

To empty the pressure tank hand valves V 109 and V107 should be opened and pump P101 switched off. Please notice that the water level of the pressure container cannot drop below the level of the lower tank B101. Maybe it can be necessary to pump water from lower to upper tank B102.



### 5.8

#### Temperature control system

The fluid process temperature of a heat exchanger shall be regulated.

The controlled temperature system used is a controlled system with self-regulation (PT1-controlled system). Because the conversion of energy happens slowly these controlled system has a big time constant (of time delay).

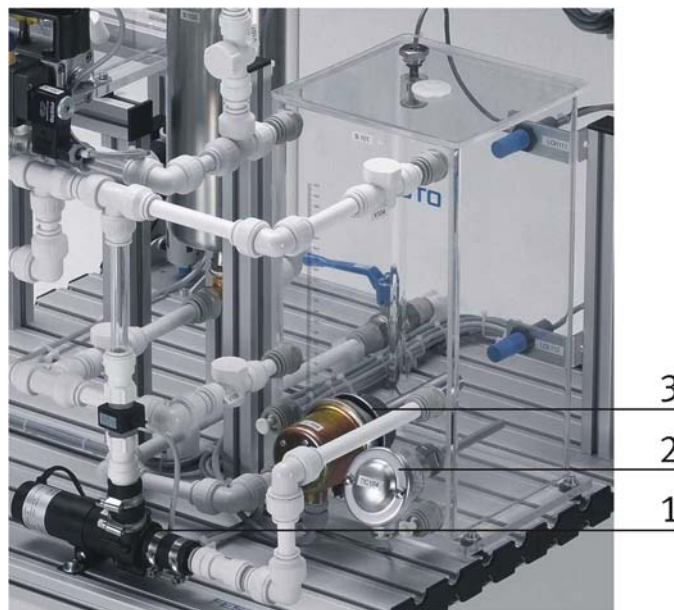

Controlled temperature system – reactor container B101 with temperatur sensor B104 (measuring point TIC 104)

The water in the reactor container B101 of the heat exchanger E104 is heated by means of a heating element and is recirculated by means of the pump P101. A PT100 sensor B104 (2) is used for measuring the system temperature at measuring point TIC 104 in the form of an actual value. The actual value should be kept on a certain temperature also if disturbances or set point changes occur.



#### Safety instructions:

- The maximum operating temperature of the tanks must not exceed +65 °C.
- Do not operate the heating unit unless the heating element is fully immersed in fluid.

The on/off switching period of the heating element E104, which is the manipulated variable, determines the heat output of the heat exchanger. For controlling system a two-point element can be used (see also EMCS block diagrams). For disturbance is it possible to use cold fluid or (f.g. ice cubes) or mix with water from the upper tank.



The switching voltage is 24 VDC and the supply voltage 230 VAC.

The resistance of the temperature sensor is connected to the measuring transformer A3. The transformer changes the resistance into a standard voltage signal 0 to 10 V. The standard voltage signal is connected to the analog terminal X2 (UE4).

The heating is controlled by a internal relay. With a digital output (O1 at XMA1) the relay can be switched on/off.

## 6 Commissioning

The Compact Workstation is generally delivered

- completely assembled
- operationally adjusted
- commissioned
- tested.



The commissioning is normally limited to a visual check to ensure correct tubing connections / pipe connections / wiring and supply of operating voltage.

All components, tubing and wiring is clearly marked so that all connections can be easily reestablished.

### 6.1 Workstation

The following is required to commission Compact Workstation:

- The assembled and adjusted Compact Workstation
- A control console
- A PLC board or controller device
- A power supply unit 24 V DC, 4.5 A
- A compressed air supply of 6 bar (600 kPa), approx. suction capacity of 50 l/min
- A PC with installed PLC programming software

### 6.2 Visual check

A visual check must be carried out before each commissioning!

Prior to starting up the station, you will need to check:

- The electrical connections
- The correct installation and condition of the pipes and pipe connections
- The correct installation and condition of the compressed air connections
- The mechanical components for visual defects (tears, loose connections etc.)

Eliminate any damage detected prior to starting up the station!

**6.3**  
**Cable connections**

All cable connections are described as an example for a Compact Workstation with Siemens S7-300 CPU313C EduTrainer Compact.

- PLC /controller – station: connect the XMA plug (1/A) of the PLC /controller with the XMA2 socket of the I/O terminal (2) of the station with a SysLink cable (3).
- PLC /controller – control console: connect the XMG plug (1/B) of the PLC /controller with the X1 socket (4) of the control console with a SysLink cable (5).
- PLC /controller – station: connect the analog plug (1/C) of the PLC /controller with the X2 socket of the analog terminal (6) of the station with a analog cable (7).
- PLC /controller – power supply unit: connect 4 mm safety plugs (red and blue) of the PLC /controller and power supply unit with 4 mm safety plugs cable (red = + / blue = —).
- PC /controller – PLC: Connect your PC to the PLC by means of a programming cable.

# Commissioning

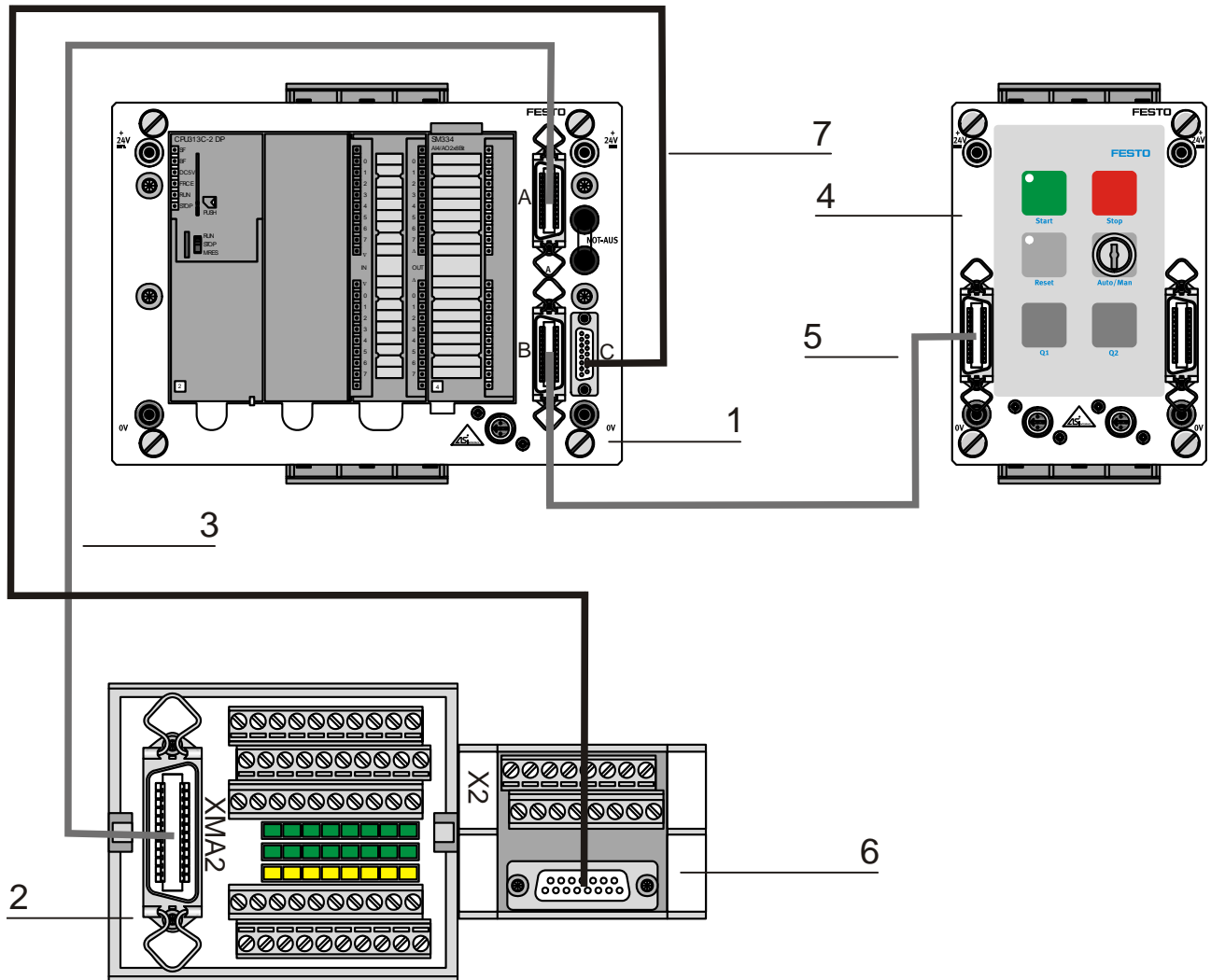

Cable connections Compact Workstation – PLC /controller, e.g. for EduTrainer Compact with S7-300 CPU 313C

Key	1	EduTrainer Compact with Siemens S7-300 CPU 313C
	2	I/O terminal SysLink
	3 + 5	SysLink-cabel, I/O- data cabel with SysLink connectors at both ends (Order-No. 034031)
	4	control panel
	6	Analog terminal
	7	Analog cabel, 15-polig, parallel (Order-No. 529141)

**6.4**

**Pneumatic connection**

- Observe technical data!
- Connect the compressed air supply to the service unit.
- Set the service unit at 6 bar (600 kPa).

**6.5**

**Voltage supply**

- The stations are supplied with 24 V DC voltage (max. 5 A) via a power supply unit. Connect the 230 VAC shock proof plug of the power supply with the main cable to the main power supply.
- The voltage supply of the complete station is effected via the PLC or controller.
- Heating element: Connect the 230 VAC shock proof plug of the power supply with the main cable to the main power supply.

**6.6**

**Choosing controlled system**

For using a specific controlled system integrated in the Compact Workstation see to following table for setup of the hand valves and actuators.

Programming, configuration or parameterizing of the PLC or closed-loop controller depends on the chosen controlled system and used signal type. E.g. at controlled level system the ultrasonic sensor is used with a signal range of 4 to 20 mA. This signal is converted into a standard voltage signal of 0 to 10 V. Therefore the signal input at the controlling system has to be configured.

Configuration of the PLC or closed-loop controller is depending on the used device. For the Compact Sytem following control types can be used:

- PLC, e.g. Simatic S7-300 CPU 313C
- industrial close-loop controller
- EasyPort analog with educational software Fluid Lab®-PA
- Simulation box digital/analog

## Commissioning

Component	Level controlled system	Flow controlled system with pump P101 for manip. value	Flow controlled system with valve V106 for manip. value	Pressure control. system with pump P101 for manip. value	Pressure control. system with valve V106 for manip. value	Temperature controlled system
Measuring point Sensor	LIC102 B101	FIC101 B102		PIC103 B103		TIC104 B104
Pump P101	controlling element	controlling element	digital On	controlling Element	digital On	On
Prop. valve V106	Off	Off	controlling element	Off	controlling element	Off
Heating element E104	Off	Off	Off	Off	Off	switched controll. element
Hand valve V101	open	closed	closed	closed	closed	closed
Ball valve V102	open/closed	closed	closed	closed	closed	closed
Hand valve V103	closed	closed	closed	open	closed	open
Hand valve V104	closed	open	closed	closed	closed	closed
Drainage valve V105	closed	closed	closed	closed	closed	closed
Hand valve V107	closed	closed	closed	closed	closed	closed
Hand valve V108	closed	closed	closed	open	open	closed
Hand valve V109	closed	closed	open	open/closed	open/closed	open
Hand valve V112	open	closed	closed	closed	closed	closed

Choosing controlled system of Compact Workstation

## 6.7

### Loading the PLC program

- PLC: Siemens S7-300 CPU 313C
  - Programming software: Siemens STEP7 Version 5.1 (SP6) or higher
1. Connect PC and PLC using the programming cable
  2. Switch on the power supply unit
  3. Switch on the compressed air supply
  4. Release the EMERGENCY-STOP switch (if available)
  5. Overall reset PLC memory (delet online MMC)
  6. CPU switch in STOP position
  7. Start the PLC programming software
  8. Dearchive the file COMPACT\_S7.zip in the directory Sources\_Quellen\ Step7\_PLC\_Program\ of the CD-ROM supplied
  9. Select the project for your PLC hardware and the s7-program "Level" and load it to the PLC
  10. CPU switch in RUN position



## 6.8 Filling and deaeration

It is recommended to use FluidLab-PA with EasyPort analog or Simulation box, digital/analog for controlling outputs:

- ball valve V102
- pump P101
- proportional valve V106

during commissioning. Also it is possible to deaerate the system by using the example S7-program "Level".

1. Before filling the system with water close drainage valve V105.
2. Before filling the system with water close all hand valves
3. Switch of power supply!  
Fill container only if power supply is switched off!  
Water spray can cause short circuits.
4. Turn off compressed air supply!
5. Fill the lower tank B101 up to a water level of 300 mm. Between 10 and 12 l water in quality of drinking water are needed. Fill up lower tank B101 with water until the upper capacitive sensor B114 is activated. Float switch S111 for overflow safety function must not be activated!
6. Clear of water spray!
7. Switch on power supply 24 VDC.
8. Switch on pump P101 and pump water to the upper tank B102. Therefore open hand valve V101 (or RESET and START program).
9. Close hand valve V101 and open hand valve V103 and prop. valve V106.
10. Close hand valve V103 and prop. valve V106.
11. Switch of pump P101 (or STOP program)
12. There will be loss of water in the piping system visible in the lower tank after deaeration. Refill lower tank and compensate the water (as described in 5.).

**6.9**  
**Commissioning sequence**  
**Compact Workstation**

For running the Compact Workstation all commissioning steps have to be obeyed according to the rules of operation:

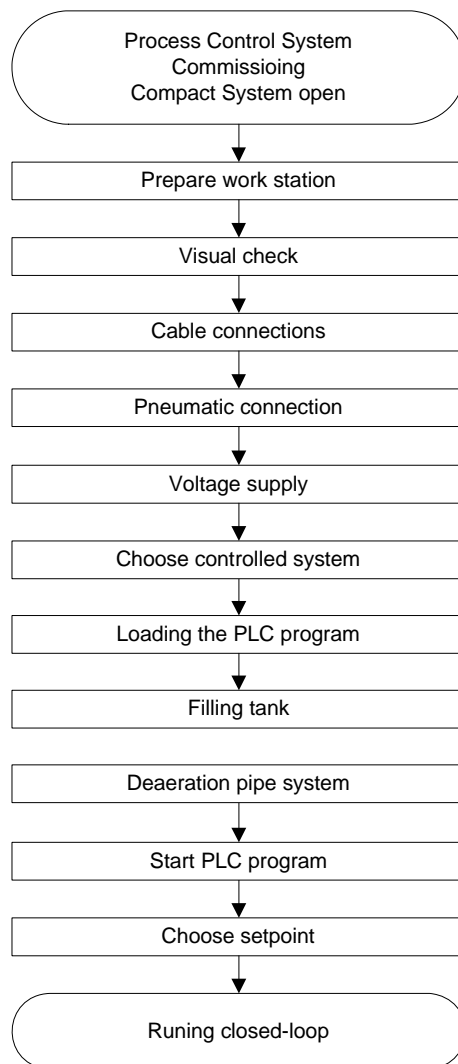

Flow chart for commissioning the Compact Workstation

**6.10**  
**Start sequence**

1. Check voltage power supply and compressed air supply.
2. Choose controlled system and setup hand valves according to commissioning table (6.6).
3. Activate RESET sequence. The RESET sequence The reset sequence is prompted by the illuminated RESET pushbutton and executed when the pushbutton has been pressed. Normal position of the station is defined if water level in lower tank is filled and following digital sensors are activated:

Float switch S111 for overflow safety	not activated
Upper limit switch B114	activated
Lower limit switch B113	activated
Float switch S112 for threshold (upper tank)	not activated

4. Start the sequence of the Compact Workstation. The start is prompted by the illuminated START pushbutton and executed when the push button has been actuated.
5. It program is started operation mode "logic control" is running and indicated with light Q1.
6. The pump P101 delivers process fluid from the lower storage tank B101 into the upper reservoir tank B102. As soon as the level raises up to the float switch B112 is activated the PLC is changing operation mode from logic control to close-loop control. Light Q2 is indicating operation mode close-loop control. Filling level is monitored with the ultrasonic sensor B102 (actual value) and controlled up to the setpoint (fixed value at startup of PLC). If the water level has reached the setpoint and the steady-state of e.g. bottling pressure is reached ball valve V102 is opened time controlled. After bottling time t the ball valve V102 is closed and once again the water level controlled to setpoint. After setpoint is reached again another bottling process is started, etc.
7. The program is stopped automatically if the water level in the lower storage tank is lower than the limit switch B113 (deactivated).

By pressing STOP pushbutton the ball valve V102 is closed and the pump P101 switched off. The sequence program is stopped.

**6.11 Notice**

- By pressing STOP or Emergency pushbutton the sequence program is stopped.
- Warning: fluid is flowing from the upper tank into the lower tank through the deactivated pump if valve V101 is open.
- Reset-sequence:  
If after STOP or start-up the system is not in normal position the reset sequence is prompted by the illuminated RESET pushbutton and executed when the pushbutton has been pressed. During RESET sequence fluid is drained from upper tank B102 to lower tank B101 therefore ball valve V102 is opened until normal position is reached.
- Setpoint and control parameter can be chosen at Step7 Online table "Closed-Loop Parameter" or at SCADA system. If the setpoint chosen is too high the water level in the lower tank is dropped below limit switch B113 and the sequence is automatically stopped. Reset system and choose a smaller setpoint!

## 7 Maintenance

The Compact Workstation is largely maintenance-free. The following should be cleaned at regular intervals using a soft fluff-free cloth or brush:

- The lenses of the optical sensors, the fibre-optics and reflectors
- The active surface of the proximity sensor
- The entire station

Do not use aggressive or abrasive cleaning agents.



Always use water in quality of drinking water. If the Compact Workstation is not used for a longer period of time all water should be drained from the system. It is recommended to clean of remaining water from the piping system and from tanks by using a vacuum cleaner for fluids. Also wipe dry with a soft fluff-free cloth.

Please notice safety information of data sheets!



## 8 Appendix

All documents are stored as pdf-files on the CD-ROM supplied.

**Designation of equipment** Compact Workstation

**Parts lists** Compact Workstation

**Process flowsheets** Compact Workstation

**EMCS block diagrams**

- Two point control of a level control system with a analog standard signal
- Continuous control of a level control system with a analog standard signal
- Continuous control of a flow rate control system with a pump as controlled system and a impulse signal for frequency measuring
- Continuous control of a flow rate control system with a proportional valve (controlled system) and a impulse signal for frequency measuring
- Continuous control of a flow rate control system with a pump as controlled system and with a analog standard signal
- Continuous control of a flow rate control system with a proportional valve as controlled system and with a analog standard signal
- Continuous control of a pressure control system with a pump as controlled system and with a analog standard signal
- Continuous control of a pressure control system with a proportional valve as controlled system and with a analog standard signal
- Two point control of a temperature control system with a analog standard signal

**Information lists**

- Two point control of a level control system with a analog standard signal
- Continuous control of a level control system with a analog standard signal
- Continuous control of a flow rate control system with a pump as controlled system and a impulse signal for frequency measuring
- Continuous control of a flow rate control system with a proportional valve (controlled system) and a impulse signal for frequency measuring
- Continuous control of a flow rate control system with a pump as controlled system and with a analog standard signal
- Continuous control of a flow rate control system with a proportional valve as controlled system and with a analog standard signal
- Continuous control of a pressure control system with a pump as controlled system and with a analog standard signal
- Continuous control of a pressure control system with a proportional valve as controlled system and with a analog standard signal
- Two point control of a temperature control system with a analog standard signal

<b>Electrical circuit diagrams</b>	Compact Workstation , electrical Control panel PLC EduTrainer Compact Siemens S7-313C
<b>Electropneumatic circuit diagrams</b>	Compact Workstation , electropneumatic
<b>Program listings</b>	S7 Symbols table S7 Overview S7 Sequential function chart S7 Function block diagram
<b>Data sheets</b>	Collection of PCS data sheets



# Allocation list

Allocation list – Symbols and addresses for CPX-FEC with 8DI/DO+8DI/DO+2AI+2AI+2AO		
Name: HEL		Date: 07.09.2004
Project name: Process Control System – Compact Workstation		
Digital Inputs		Page 1 of 3
Description	Equipment identifier / symbol	Address FEC-CPX
Digital Inputs Station		
Flow rate sensor (frequency 0...1000Hz)	B101	I 0.0
Float switch (nc) overflow safety tank B101, measuring point LS+101	S111	I 0.1
Float switch threshold function tank B102 (no), measuring point LS-102	S112	I 0.2
Proximity switch min. lower tank B101, measuring point LO-101,	B113	I 0.3
Proximity switch max. level lower tank B101, measuring point LO+101	B114	I 0.4
Micro switch ball valve V102 open	S115	I 0.5
Micro switch ball valve V102 close	S116	I 0.6
nc	-	I 0.7
Digital inputs control panel		
Start pushbutton (no)	S1	I 1.0
Stop pushbutton (nc)	S2	I 1.1
Automatic-Manual key switch	S3	I 1.2
Reset pushbutton (no)	S4	I 1.3
nc	-	I 1.4
nc	-	I 1.5
nc	-	I 1.6
nc	-	I 1.7

# Allocation list

Allocation list – Symbols and addresses for CPX-FEC with 8DI/DO+8DI/DO+2AI+2AI+2AO		
Name: HEL		Date: 07.09.2004
Project name: Process Control System – Compact Workstation		
Digital Outputs		Page 2 of 3
Description	Equipment identifier / symbol	Address FEC-CPX
Digital Outputs Station		
Process valve, open ball valve V102 with NAMUR valve Y102	Y102	O 0.0
Turn on heating unit tank 101	E104	O 0.1
Preset pump P101 0=digital/1=analog	PumpPreset	O 0.2
Pump P101 turn on/off digital	PumpOn	O 0.3
Proportional valve V106 turn on electronic module	V106_On	O 0.4
nc	-	O 0.5
nc	-	O 0.6
nc	-	O 0.7
Digital outputs control panel		
Start indicator light	H1	O 1.0
Reset indicator light	H2	O 1.1
Q1 indicator light – open control operation mode	H3	O 1.2
Q2 indicator light - closed-loop control operation mode	H4	O 1.3
nc	-	O 1.4
nc	-	O 1.5
nc	-	O 1.6
nc	-	O 1.7

## Zuordnungsliste

Allocation list – Symbols and addresses for CPX-FEC with 8DI/DO+8DI/DO+2AI+2AI+2AO		
Name: HEL		Date: 07.09.2004
Project name: Process Control System – Compact Workstation		
Analog Inputs and Outputs		Page 1 of 3
Description	Equipment identifier / symbol	Address FEC-CPX
Analoge Eingänge Station		
Analogeingang Kanal 0 Füllstand (UE1 = 0...10 V)	AI_Level	IW 64
Analogeingang Kanal 1 Durchfluss (UE2 = 0...10 V)	AI_Flow	IW65
Analogeingang Kanal 2 Druck (UE3 = 0...10 V)	AI_Pres	IW66
Analogeingang Kanal 3 Temperatur (UE4 = 0...10 V)	AI_Temp	IW67
Analoge Ausgänge Station		
Analogausgang Kanal 0 Pumpendrehzahl P101	AO_Pump	OW 64
Analogausgang Kanal 1 Proportionalventil Hub V106	AO_Valve	OW 65